

Fisher™ 3710 and 3720 Valve Positioners and 3722 Electro-Pneumatic Converter

Contents

Introduction	2
Scope of Manual	2
Description	2
Positioner to Actuator Mountings List	5
Specifications	6
Educational Services	6
Installing the 3722 Converter	6
Hazardous Area Classifications and Special Instructions for “Safe Use” and Installation in Hazardous Areas for 3722 Converter	7
Installation	8
Mounting the Positioner	8
Installing the 3710 or 3720 Pneumatic Positioner on Size 25 or 50 585 and 585R Actuators	13
Connections	15
Supply Connection	16
Output Connections	17
Instrument Connection	17
Vent Opening, Purge Option, and Actuator Vent Connection	17
Connecting the Purge Tube	19
Electrical Connection for the 3720 Positioner	19
Diagnostic Connections	20
Calibration	22
Setting the Initial Cam Position	22
Zero and Span Adjustments	23
Standard or Beacon Indicator Alignment	24
Changing Positioner Action	25
Single-Action/Double-Action	26
Direct-Action/Reverse-Action	26
Split-Range Operation	27
Changing the Spool Valve (To Increase Positioner Output Capacity)	27
Changing the Span Adjuster Assembly (To Change Positioner Input Range)	29
Principle of Operation	30

Figure 1. Positioners



3720 POSITIONER MOUNTED
ON 1052 ACTUATOR



3710 POSITIONER MOUNTED
ON 1066 ACTUATOR

Contents (cont'd)

Maintenance	31	Assembling the Feedback Shaft (Cam Shaft)	39
Positioner Maintenance	31	Replacing the Feedback Arm Assembly and Span Adjuster Assembly	39
Replacing the Standard or Beacon Indicator	31	3722 Converter Maintenance	39
Removing the 3722 Converter	32	Replacing the Converter Primary O-Ring and Filter	39
Removing the Positioner	32	Disassembling the 3722 Converter	40
Removing the Feedback Arm Assembly	33	Assembling the 3722 Converter	40
Disassembling the Feedback Arm Assembly and Span Adjuster Assembly	34	Testing the 3722 Converter Module	41
Removing the Feedback Shaft (Cam Shaft)	34	Parts Ordering	41
Disassembling the Spool Valve, Action Block, and Gasket	34	Parts Kits	41
Disassembling the Input Module and Summing Beam Assembly	35	Parts List	41
Replacing the Input Module Diaphragm	36	Positioner Common Parts	42
Assembling the Input Module and Summing Beam Assembly	37	Diagnostic Connections	45
Assembling the Spool Valve, Action Block, and Gasket	38	3722 Electro-Pneumatic Converter	46
		Positioner Mounting Parts	47
		Mounting Parts for Mounting Positioner on 585 and 585R Actuators	50
		Fittings	50

Introduction

Scope of Manual

This instruction manual includes installation, operation, calibration, maintenance, and parts ordering information for the Fisher 3710 pneumatic positioner and 3720 electro-pneumatic positioner.

This manual also provides field installation and maintenance information for the Fisher 3722 electro-pneumatic converter. Refer to separate instruction manuals for information on the actuator, control valve, and other accessories.

Do not install, operate, or maintain a 3710 pneumatic positioner, a 3720 electro-pneumatic positioner or a 3722 electro-pneumatic converter without being fully trained and qualified in valve, actuator and accessory installation, operation and maintenance. **To avoid personal injury or property damage it is important to carefully read, understand, and follow all of the contents of this manual, including all safety cautions and warnings.** If you have any questions about these instructions, contact your [Emerson sales office](#) or Local Business Partner before proceeding.

Description

The 3710 pneumatic positioner and 3720 electro-pneumatic positioner are used with either diaphragm actuators (spring return) or piston rotary actuators (spring return or double-action) as shown in figure 1. These positioners provide a valve ball or disk position for a specific input signal. These positioners can easily be configured to provide single- or double-action output for rotary actuators.

The 3710 pneumatic positioner accepts a pneumatic input signal. The 3720 electro-pneumatic positioner accepts a milliampere (mA), direct current (DC), input signal. Refer to table 1 for an explanation of type numbers.

The 3710 pneumatic positioner provides a valve position for a standard pneumatic input signal. The positioner may also be split-ranged. See table 3 for input signal ranges.

The 3720 electro-pneumatic positioner provides a valve position for a milliampere (mA), direct current (DC), input signal. The positioner may also be split-ranged. See table 3.

Table 1. Specifications

<p>Available Configurations</p> <p>The Fisher 3700 series of positioners include the following models:</p> <p>3710: ■ Single- or ■ double-acting pneumatic rotary valve positioner</p> <p>3720: ■ Single- or ■ double-acting electro-pneumatic rotary valve positioner consisting of a 3710 with a 3722 attached</p> <p>3722: An electro-pneumatic converter that converts a 4-20 mA DC input signal to a 0.2 to 1.0 bar (3 to 15 psig) signal for the pneumatic positioner</p> <p>Input Signal</p> <p>3710: <i>Standard:</i> ■ 0.2 to 1.0 bar (3 to 15 psig) or ■ 0.4 to 2.0 bar (6 to 30 psig) <i>Split-Range:</i> ■ 0.2 to 0.6 bar (3 to 9 psig) and 0.6 to 1.0 bar (9 to 15 psig) or ■ 0.4 to 1.2 bar (6 to 18 psig) and 1.2 to 2.0 bar (18 to 30 psig)</p> <p>3720: <i>Standard:</i> ■ 4-20 mA DC constant current with 30 VDC maximum compliance voltage <i>Split-Range:</i> ■ 4-12 mA DC or 12-20 mA DC</p> <p>Equivalent Circuit</p> <p>3720: 120 ohms shunted by three 5.6 V zener diodes. See figure 15.</p> <p>Output Signal</p> <p>Pneumatic pressure as required by the actuator up to full supply pressure</p> <p>Action⁽¹⁾: Field-reversible between ■ direct and ■ reverse within the pneumatic positioner</p> <p>Supply Pressure⁽²⁾</p> <p><i>Recommended:</i> 0.3 bar (5 psig) above actuator requirement</p> <p><i>Maximum:</i> 10.3 bar (150 psig) or maximum pressure rating of the actuator, whichever is lower</p> <p>Supply Medium</p> <p>3710: Air or Natural Gas</p> <p>3720: Air</p> <p>Supply medium must be clean, dry, and noncorrosive</p> <p>Per ISA Standard 7.0.01</p> <p>A maximum 40 micrometer particle size in the air system is acceptable. Further filtration down to 5 micrometer particle size is recommended. Lubricant</p>	<p>content is not to exceed 1 ppm weight (w/w) or volume (v/v) basis. Condensation in the air supply should be minimized</p> <p>Per ISO 8573-1</p> <p><i>Maximum particle density size:</i> Class 7</p> <p><i>Oil content:</i> Class 3</p> <p><i>Pressure Dew Point:</i> Class 3 or at least 10°C less than the lowest ambient temperature expected</p> <p>3720 positioners are not approved for use with natural gas as the supply medium</p> <p>Steady-State Air Consumption⁽³⁾</p> <p>3710: <i>6 mm Standard Spool Valve:</i> 0.82 normal m³/hr (29 scfh) at 4.1 bar (60 psig) supply pressure</p> <p>3720: <i>6 mm Spool Valve:</i> 1.0 normal m³/hr (36 scfh) at 4.1 bar (60 psig) supply pressure</p> <p>Maximum Supply Air Demand⁽³⁾ (Double Acting Output)</p> <p><i>6 mm Spool Valve:</i> 20 normal m³/hr (700 scfh) at 4.1 bar (60 psig) supply pressure</p> <p>Typical Performance⁽⁴⁾</p> <p>3710: <i>Independent Linearity:</i> ±0.5% of output span <i>Hysteresis:</i> 0.5% of output span <i>Deadband:</i> 0.3% of input span</p> <p>3720: <i>Independent Linearity:</i> ±1.0% of output span <i>Hysteresis:</i> 0.6% of output span <i>Deadband:</i> 0.35% of input span</p> <p>Electromagnetic Compatibility for 3722</p> <p>Meets EN 61326-1:2013</p> <p>Immunity—Industrial locations per Table 2 of the EN 61326-1 standard. Performance is shown in table 2 below.</p> <p>Emissions—Class A</p> <p>ISM equipment rating: Group 1, Class A</p> <p>Note: Electromagnetic Interference (EMI) specifications also apply to 3720 positioners</p> <p>Operating Influences</p> <p>Supply Pressure Sensitivity: A 10% change in supply pressure changes the valve shaft position less than the following percentages of valve rotation:</p> <p>3710: 1.0% at 4.1 bar (60 psig) supply pressure</p> <p>3720: 1.5% at 4.1 bar (60 psig) supply pressure</p>
--	--

- continued -

Table 1. Specifications (Continued)

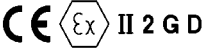
<p>Operative Temperature Limits⁽²⁾</p> <p>■ -40 to 80°C (-40 to 180°F), ■ -50 to 107°C (-58 to 225°F)</p> <p>Hazardous Area Classification for 3710 Positioner</p> <p>3710 pneumatic positioners comply with the requirements of ATEX Group II Category 2 Gas and Dust</p> <p> II 2 G D</p> <p>Electrical Classifications for 3722 Converter</p> <p>CSA— Intrinsicly Safe, Explosion-proof, Type n, Dust Ignition-proof FM— Intrinsicly Safe, Explosion-proof, Type n, Dust Ignition-proof, Non-incendive ATEX— Intrinsicly Safe, Flameproof, Type n IECEX— Intrinsicly Safe, Flameproof, Type n</p> <p>Note: These classifications also apply to the 3720 positioner</p> <p>Housing Classification for 3722 Converter</p> <p>CSA— Type 3 Encl. ATEX— IP64 FM— NEMA 3, IP54 IECEX— IP54</p> <p>Mount instrument with vent on side or bottom if weatherproofing is a concern.</p> <p>Note: These classifications also apply to the 3720 positioner</p> <p>Other Classifications/Certifications for 3722 Converter</p> <p>CUTR—Customs Union Technical Regulations (Russia, Kazakhstan, Belarus, and Armenia)</p>	<p>INMETRO— National Institute of Metrology, Quality and Technology (Brazil) KGS— Korea Gas Safety Corporation (South Korea)</p> <p>Contact your Emerson sales office or Local Business Partner for classification/certification specific information</p> <p>Pressure Connections</p> <p>1/4 NPT internal</p> <p>Electrical Connection for 3720 Positioner</p> <p>1/2-14 NPT conduit connection</p> <p>Rotary Valve Rotation</p> <p>■ 90 degrees (standard) ■ 60 degrees (optional)</p> <p>Approximate Weight</p> <p>3710: 2.04 kg (4.5 pounds) 3720: 2.72 kg (6.0 pounds)</p> <p>Declaration of SEP</p> <p>Fisher Controls International LLC declares this product to be in compliance with Article 4 paragraph 3 of the PED Directive 2014/68/EU. It was designed and manufactured in accordance with Sound Engineering Practice (SEP) and cannot bear the CE marking related to PED compliance.</p> <p>However, the product <i>may</i> bear the CE marking to indicate compliance with <i>other</i> applicable European Community Directives.</p>
--	---

NOTE: Specialized instrument terms are defined in ANSI/ISA Standard 51.1 - Process Instrument Terminology.

1. For direct action, an increasing input signal extends actuator rod. For reverse action, an increasing input signal retracts actuator rod.

2. The pressure and temperature limits in this document, and any applicable code or standard limitation should not be exceeded.

3. Normal cubic meters per hour (0°C and 1.01325 bar absolute). Scfh — standard cubic feet per hour (60°F and 14.7 psia).

4. Typical values tested using a 1061 size 30 actuator at 4.1 bar (60 psig) supply pressure. Performance may vary with other actuator types and supply pressures.

Table 2. Fisher 3722 Electro-Converter⁽¹⁾ EMC Summary Results—Immunity

Port	Phenomenon	Basic Standard	Test Level	Performance Criteria ⁽²⁾
Enclosure	Electrostatic Discharge (ESD)	IEC 61000-4-2	4 kV contact 8 kV air	A
	Radiated EM field	IEC 61000-4-3	80 to 1000 MHz @ 10V/m with 1 kHz AM at 80% 14000 to 2000 MHz @ 3V/m with 1 kHz AM at 80% 2000 to 2700 MHz @ 1V/m with 1 kHz AM at 80%	A
	Rated power frequency magnetic field	IEC 61000-4-8	60 A/m at 50 Hz	A
I/O signal/control	Burst (fast transients)	IEC 61000-4-4	1 kV	A
	Surge	IEC 61000-4-5	1 kV (line to ground only, each)	B
	Conducted RF	IEC 61000-4-6	150 kHz to 80 MHz at 3 Vrms	A

Specification limit = ±1% of span

1. The information contained in this table also applies to the 3720 positioner.

2. A = No degradation during testing. B = Temporary degradation during testing, but is self-recovering.

Table 3. Input Signal Range

POSITIONER	INPUT SIGNAL RANGE	
	Pneumatic	Electronic
3710 w/3 to 15 psig span adj. ass'y (no color coding)	<ul style="list-style-type: none"> ■ 0.2 to 1.0 bar (3 to 15 psig) ■ 0.2 to 0.6 bar (3 to 9 psig) and 0.6 to 1.0 bar (9 to 15 psig), split-ranging 	---
3710 w/6 to 30 psig span adj. ass'y (red color coding)	<ul style="list-style-type: none"> ■ 0.4 to 2.0 bar (6 to 30 psig) ■ 0.4 to 1.2 bar (6 to 18 psig) and 1.2 to 2.0 bar (18 to 30 psig), split-ranging 	---
3720	---	<ul style="list-style-type: none"> ■ 4-20 mA DC ■ 4-12 mA DC or 12-20 mA DC, split-ranging

Positioner to Actuator Mountings List

The positioner mounts directly to the actuator cover plate of Fisher 1051, 1052, and 1061 actuators. See table 4 for actuator sizes.

Figure 2 shows a positioner ready for mounting on a piston rotary actuator. A mounting plate (key 43) is used to mount the positioner base plate to Fisher 1051, 1052, 1061, 1066, and 2052 actuators. See table 4 for actuator sizes.

The positioner also mounts on a Fisher 585 and 585R size 25 or 50 sliding-stem actuator. A mounting plate (key 43) is used to mount the positioner base plate to the actuator.

Figure 2. Mounting the Positioner Base Plate

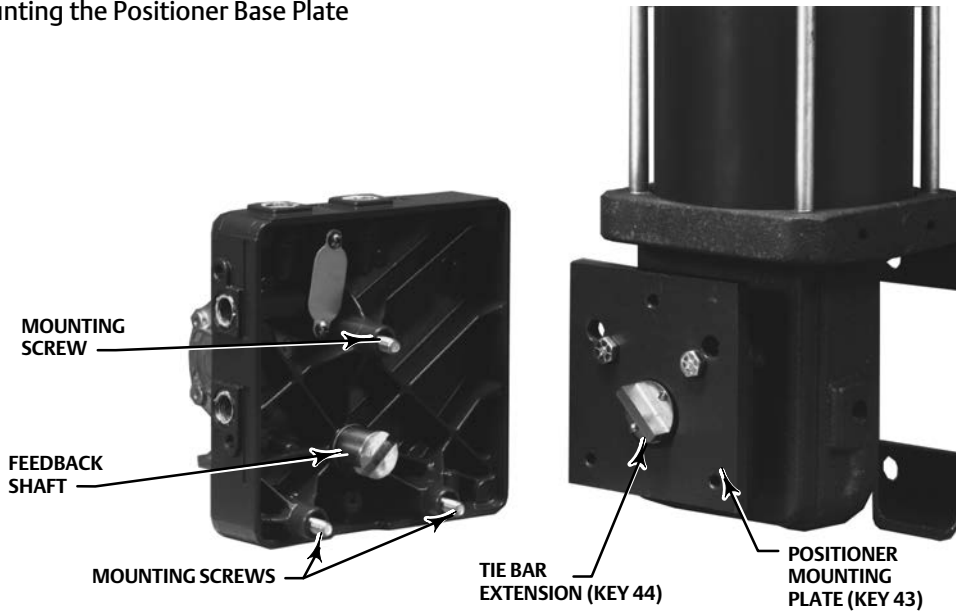

W6059-1

Table 4. Positioner to Actuator Mountings

POSITIONER TO ACTUATOR MOUNTINGS	
Direct Mounting to Actuator Cover Plate ⁽¹⁾	Mounting Plate Required
<ul style="list-style-type: none"> •1051, size 30⁽²⁾, 40, and 60 •1052, sizes 30⁽²⁾, 40, 60, and 70 •1061, size 30, 40, 60, and 68 	<ul style="list-style-type: none"> •1051, size 33 •1052, size 20, 33 •1061, size 80, 100 •1066, size 20, 27, and 75 •2052, size 1, 2, and 3 •NAMUR Mounting
<p>1. Includes purge tube option. 2. The size 30 actuator is no longer manufactured by Emerson. 3710 and 3720 positioners are available for field installation on existing size 30 actuators.</p>	

Specifications

Specifications are shown in table 1.

Educational Services

For information on available courses for 3710 pneumatic positioners or 3720 electro-pneumatics positioners, as well as a variety of other products, contact:

Emerson Automation Solutions
Educational Services, Registration
Phone: +1-641-754-3771 or +1-800-338-8158
e-mail: education@emerson.com
emerson.com/fishervalvetraining

Installing the 3722 Converter

See figure 3.

⚠ WARNING

Avoid personal injury from sudden release of process pressure. Before mounting the 3720 electro-pneumatic positioner or 3722 electro-pneumatic converter:

- **Wear protective eyewear, gloves and clothing whenever possible.**
- **Do not remove the actuator from the valve while the valve is still pressurized.**
- **Disconnect any operating lines providing air pressure, electric power, or a control signal to the actuator. Be sure the actuator cannot suddenly open or close the valve.**
- **Use bypass valves or completely shut off the process to isolate the valve from process pressure. Relieve process pressure on both sides of the valve.**
- **Relieve any supply or output pressure in the existing positioner.**
- **When installing an electro-pneumatic positioner or converter in a hazardous area, turn off control signals until installation is complete. Be sure all safety barriers, connections, and the converter housing cap and O-ring are properly installed before supply a control signal to the unit.**

- Use lock-out procedures to be sure that the above measures stay in effect while you work on the equipment.
 - Do not open where an explosive dust atmosphere is present.
 - Check with your process or safety engineer for any additional measures that must be taken to protect against process media.
-

⚠ WARNING

The positioner can provide full supply pressure to any connected equipment. To avoid personal injury and equipment damage, make sure supply pressure never exceeds the maximum safe working pressure of any connected equipment.

CAUTION

Do not use sealing tape on pneumatic connections. This instrument contains small passages that may become obstructed by detached sealing tape. Thread sealant paste should be used to seal and lubricate pneumatic threaded connections.

Hazardous Area Classifications and Special Instructions for “Safe Use” and Installation in Hazardous Locations for 3722 Converter

Refer to the following instruction manual supplements for approval information.

- CSA Hazardous Area Approvals - Fisher 3722 Electro-Pneumatic Converter ([D104315X012](#))
- FM Hazardous Area Approvals - Fisher 3722 Electro-Pneumatic Converter ([D104316X012](#))
- ATEX Hazardous Area Approvals - Fisher 3722 Electro-Pneumatic Converter ([D104317X012](#))
- IECEx Hazardous Area Approvals - Fisher 3722 Electro-Pneumatic Converter ([D104318X012](#))

All documents are available from your [Emerson sales office](#) or Local Business Partner, or visit our website at www.Fisher.com. Contact your Emerson sales office or Local Business Partner for all other approval/certification information.

Installation

To change an existing 3710 positioner into a 3720 positioner, install a 3722 electro-pneumatic converter (figure 3). The 3722 electro-pneumatic converter mounts over the input and supply connections of the 3710 positioner.

Figure 3. Fisher 3722 Electro-Pneumatic Converter

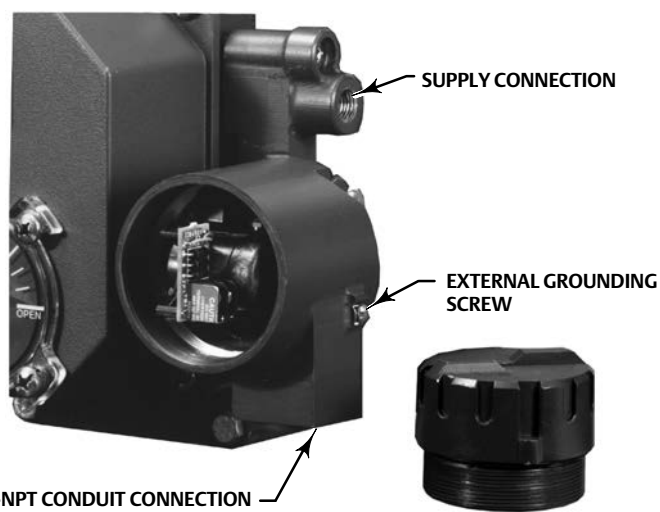

1. Be sure all safety procedures have been followed. Remove the input and supply connections from the existing 3710 base plate and clean the ports.
2. Locate the two O-rings (key 85, figure 32) and properly lubricate (key 82) them. Place one O-ring in the recessed area surrounding the input port on the positioner base plate. Place the other O-ring around the supply port.
3. Locate the two socket head mounting screws (key 84). Properly orient the converter and secure it to the positioner base plate with the mounting screws. Be sure the O-rings remain in place while securing the converter to the positioner base plate.
4. Connect supply pressure to the converter supply port.

Mounting the Positioner

Typically, a positioner is ordered with an actuator. At the factory, the positioner is mounted on the actuator and calibrated. However, a positioner can be ordered separately and mounted on an existing actuator.

To field-mount a positioner to an existing actuator, an actuator cover plate with mounting holes and purge tube knockout may be required. Check the existing actuator cover plate. It must have three positioner mounting holes and, for specific actuators, a purge tube knockout. See table 4.

If the proper mounting holes are present, perform the following mounting procedure and then follow the calibration procedures in this instruction manual. Refer to the appropriate instruction manuals for actuator and valve mounting procedures.

⚠ WARNING

Avoid personal injury from sudden release of process pressure. Before mounting the 3720 electro-pneumatic positioner or 3722 electro-pneumatic converter:

- **Wear protective eyewear, gloves and clothing whenever possible.**
 - **Do not remove the actuator from the valve while the valve is still pressurized.**
 - **Disconnect any operating lines providing air pressure, electric power, or a control signal to the actuator. Be sure the actuator cannot suddenly open or close the valve.**
 - **Use bypass valves or completely shut off the process to isolate the valve from process pressure. Relieve process pressure on both sides of the valve.**
 - **Vent the power actuator loading pressure and relieve any actuator spring precompression.**
 - **Use lock-out procedures to be sure that the above measures stay in effect while you work on the equipment.**
 - **When installing a positioner or converter in a hazardous area, turn off control signals until installation is complete. Be sure all safety barriers, connections, and the converter housing cap and O-ring are properly installed before supplying a control signal to the unit.**
 - **Check with your process or safety engineer for any additional measures that must be taken to protect against process media.**
-

⚠ WARNING

The positioner can provide full supply pressure to any connected equipment. To avoid personal injury and equipment damage, make sure supply pressure never exceeds the maximum safe working pressure of any connected equipment.

Note

The positioner mounts directly to the actuator cover plate of several Fisher actuators. See table 4. To directly mount the positioner to an existing Fisher actuator, you must use an actuator cover plate with three positioner mounting holes and the 5/8-inch purge option knockout plug.

See the parts list for the specific actuator cover plate required above to integrally mount the positioner.

See figures 4 and 33 for positioner mounting drawings.

Note

To mount the positioner to an actuator with an existing Fisher 3610 positioner, remove the 3610 positioner and replace it with an appropriate metal cover plate and four cap screws. For assistance, contact your [Emerson sales office](#) or Local Business Partner.

Figure 4. Typical Positioner/Actuator Combinations

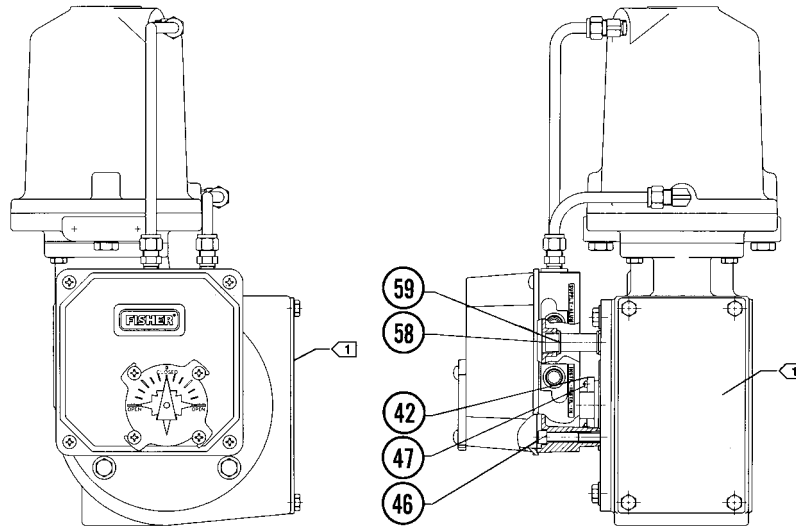

4288466-A

**3710 POSITIONER MOUNTED ON A
1061 SIZE 30 ACTUATOR**

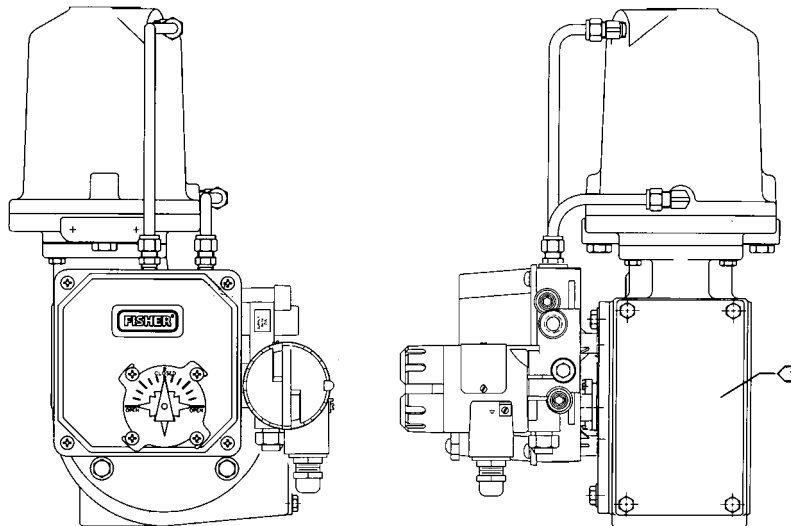

4288466-A

**3720 POSITIONER MOUNTED ON A
1061 SIZE 30 ACTUATOR**

NOTES:
FIGURE 33 SHOWS ADDITIONAL POSITIONER/ACTUATOR COMBINATIONS
1 ACTUATOR COVER PLATE REQUIRED WHEN REPLACING AN INSTALLED 3610 POSITIONER

1. See figure 5 for a typical actuator. Remove the actuator travel indicator machine screws, travel indicator, and actuator cover cap screws.

Note

When removing the actuator cover plate, take care not to change the position of the rod end bearing on the end of the turnbuckle inside the actuator housing.

2. If necessary, install a new cover plate.
 - a. Remove the existing cap screws and actuator cover plate from the actuator housing.
 - b. Remove the retaining ring (e-clip) and hub from the cover plate.
 - c. Install the hub and retaining ring into the new actuator/positioner cover plate.

Note

Position the actuator cover plate so the positioner mounting holes on the new cover plate allow placement of the positioner in the desired orientation.

Actuator cover alignment on the 1052 actuator can be aided by moving the actuator slightly away from its “up” travel stop using a regulated air source. If the hole alignment cannot be obtained in this manner, temporarily loosen the cap screws that secure the housing to the mounting yoke and shift the housing slightly. Do not completely travel the actuator while the cover is removed.

Tighten the actuator cap screws before continuing.

3. Position the new actuator/positioner cover plate so the positioner mounting holes on the new cover plate allow placement of the new positioner in the desired orientation. Secure the new cover plate to the actuator.
4. Install the positioner tie bar (key 42) in place of the travel indicator on the actuator hub.

Note

Before installation of the positioner mounting plate (key 43), review the mounting drawings (figures 4 and 33). Properly align the positioner mounting plate before attaching the mounting plate to the actuator cover plate. Note that the three positioner mounting holes must be aligned to match the three mounting screws which will pass through the base of the positioner.

5. If the specific actuator requires a positioner mounting plate (key 43), install the mounting plate using the cap screws (key 45).
6. Unscrew the four captive cover screws and remove the cover assembly (key 7) from the positioner.
7. See figure 6. Loosen the cam locknut (key 37) and rotate the feedback shaft (key 38) as necessary to align the slot in the feedback shaft end with the tie bar on the actuator hub. Tighten the cam locknut.
8. Align the positioner with the mounting holes in the new actuator cover plate or positioner mounting plate. Be sure that the tie bar fits securely into the feedback shaft end slot. Secure the positioner to the actuator cover plate or mounting plate using the (hex) socket head cap screws (key 46).
9. Before installing the positioner cover, properly align the valve position indicator (standard, low-profile indicator or optional beacon indicator). Follow the standard or beacon indicator alignment procedure given in this instruction manual. Then, install the positioner cover assembly.

Figure 5. Typical Piston Actuator (Fisher 1061)

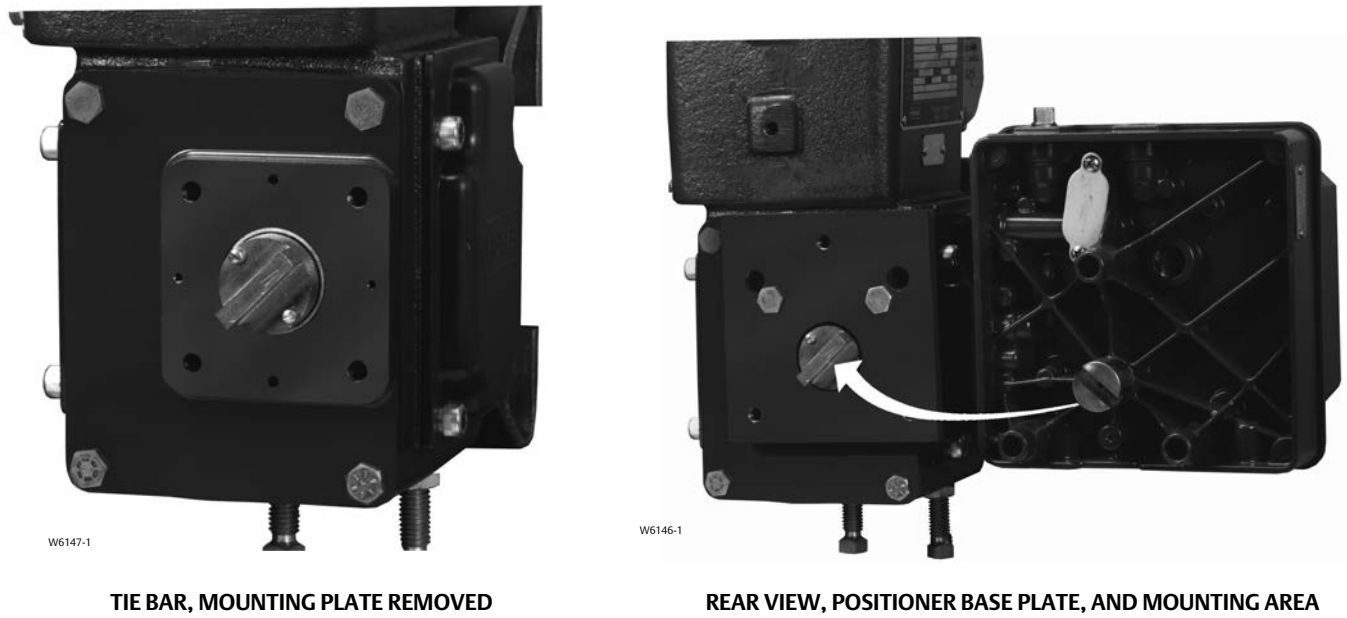
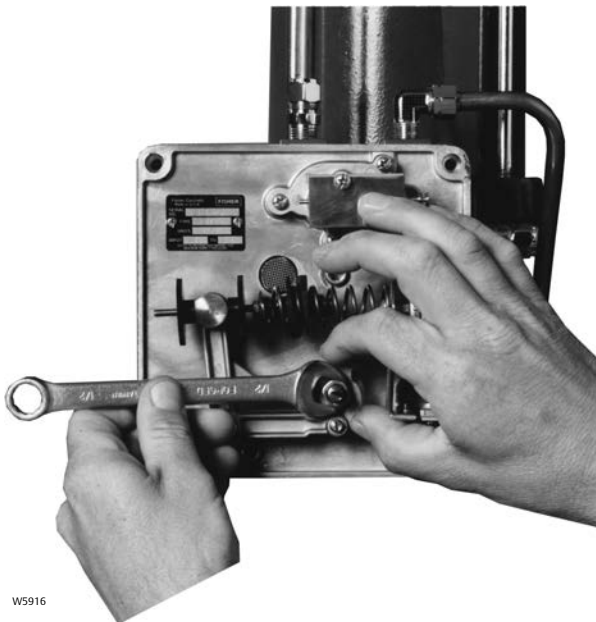

Figure 6. Loosening the Cam Locknut



Installing the 3710 or 3720 Pneumatic Positioner on Size 25 or 50 585 and 585R Actuators

Refer to figures 7, 8, and 9 for key number locations unless noted otherwise.

Figure 7. Typical Fisher 3710 Positioner Mounted on a 585 Actuator

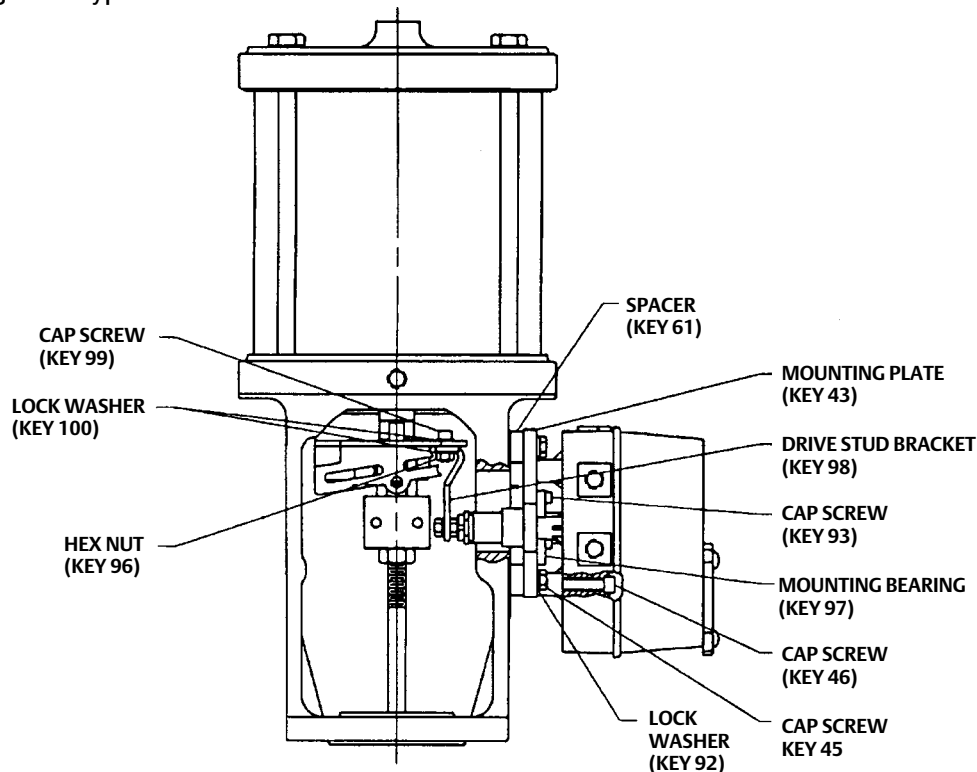

1. An actuator stem bracket is supplied with the positioner. Assemble the various positioner feedback parts to the stem bracket as follows:
 - a. Refer to figure 8. Install the roller bearing (key 101) on the drive stud (key 95) and secure with the E-ring (key 102).
 - b. Refer to figure 9. Attach the drive stud (with roller bearing) to the drive stud bracket (key 98) with 1/4-inch hex nut (key 96), lock washer (key 100), and flat washer (key 103). Place the flat washer between the lock washer and the hex nut. The washers and hex nut should all be on the same side of the drive stud bracket as shown in figure 9. The flat washer may be moved to the other side of the drive stud (between the drive stud and the drive stud bracket) if extra space is required to position the roller bearing near the center of the feedback lever. Leave the hex nut loose for later adjustment.
 - c. Attach the drive stud bracket (with drive stud) to the actuator stem bracket using two cap screws (key 99), two lock washers (key 100), and two hex nuts (key 96). Leave the hex nuts loose for later adjustment.
2. Stroke the actuator from the top stop to the bottom stop, and record the travel.

In steps 3 through 6, refer to the actuator instruction manual for key number locations unless noted otherwise.

3. Loosen eight screws, and remove the front and back yoke covers (keys 18 and 20).
4. Loosen the two cap screws in the stem connector assembly (key 15) and remove the stem connector. Separate the actuator piston stem (key 12) from the valve plug stem.

Figure 8. Drive Stud and Roller Bearing Assembly

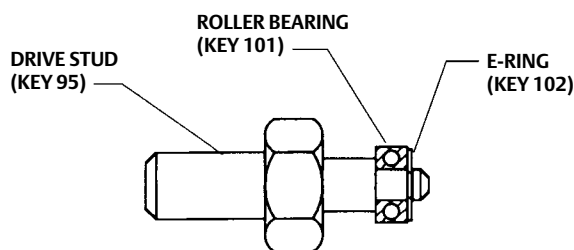
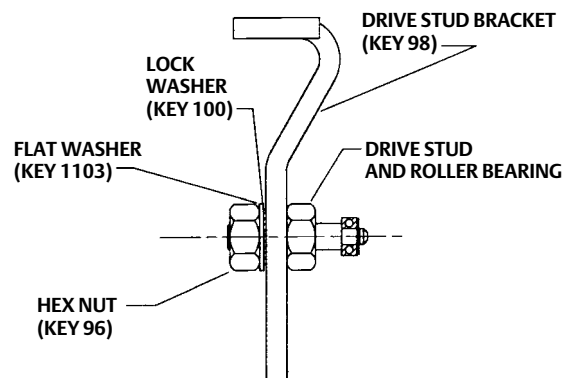

Figure 9. Drive Stud Bracket with Drive Stud and Roller Bearing Assembly

**Note**

Before performing the next step, position the valve plug stem at the lower end of its travel. Position the actuator stem at the upper travel stop. Check for sufficient clearance between the actuator stem and the valve stem to allow removing the stem bracket assembly. If there is insufficient clearance, remove the actuator from the valve.

5. Loosen the stem bracket retainer (key 14) and let it slide down over the valve plug stem. Remove the stem bracket assembly (key 13).
6. Install the stem bracket assembly (with drive stud and drive stud bracket) on the actuator stem. Align the stem bracket assembly so that it will be parallel with the back yoke cover. Install the stem bracket retainer and tighten to 68 N•m (50 lbf•ft). If the actuator was removed from the valve, install the actuator on the valve. Do not attach the stem connector at this time.
7. Attach the mounting bearing (key 97) to the mounting plate (key 43) with three hex socket cap screws (key 93).
8. Refer to the actuator instruction manual. Loosen the four screws, and remove the actuator blanking plate.
9. Attach the positioner mounting plate to the actuator yoke as shown in figure 10 with four spacers (keys 61), four cap screws (key 45) and lock washers (key 92).
10. Loosen the four captive cover screws and remove the positioner cover.
11. Loosen the cam locknut (key 37, figure 31).
12. Attach the positioner to the mounting plate with three hex socket cap screws (key 46). Make sure that the positioner feedback shaft (key 38, figure 31) rotates freely and is not binding with the mounting bearing, adjust if necessary.
13. Attach the feedback lever (key 94) to the end of the feedback shaft with the two hex socket cap screws (key 93). The markings on the feedback lever should be visible when looking toward the back of the positioner. Make sure the roller bearing (key 101) on the drive stud engages the slot in the feedback lever.

⚠ WARNING

An unexpected change in actuator supply pressure while performing the following steps could result in personal injury. Use lockout procedures to ensure a stable air supply.

14. Perform the Actuator Mounting procedure steps 2 through 8 in the actuator instruction manual to reconnect the actuator stem and valve stem.

15. Make sure the cam locknut (key 37, figure 31) is loose, then stroke the valve/actuator to mid-travel. Adjust the drive stud location vertically so that the feedback lever is perpendicular to the stem. Tighten the hex nut attached to the drive stud.
16. Refer to figure 11. Adjust the position of the drive stud bracket so that the center of the roller bearing aligns with the appropriate travel mark on the feedback lever.
17. Tighten the cap screws to secure the drive stud bracket to the stem bracket. If necessary, readjust the drive stud position to keep the feedback lever perpendicular to the stem.
18. Make the output, supply, instrument, and vent connections as described in the Connection section. Calibrate the positioner by performing the procedures in the Calibration section.
19. Replace the actuator front and back yoke covers. Discard the actuator blanking plate and four screws.

Figure 10. Mounting Plate Positioned on Actuator

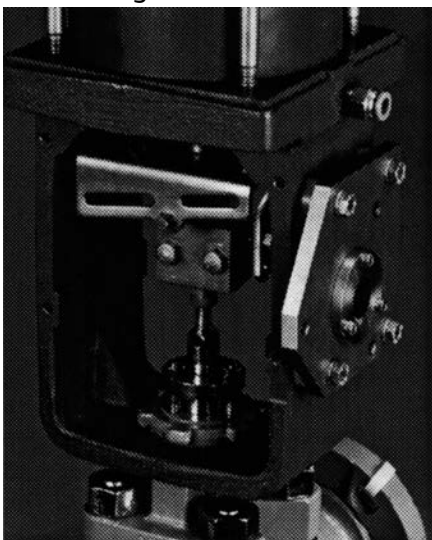

W8461

Figure 11. Positioning Drive Stud in Feedback Lever

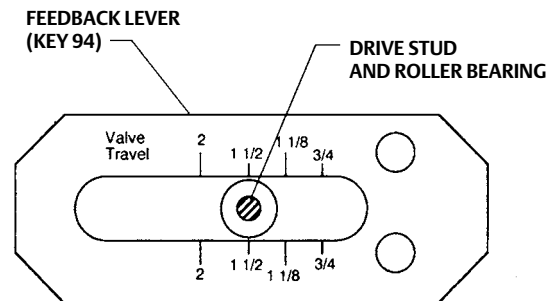

Connections

⚠ WARNING

The positioner is capable of providing full supply pressure to connected equipment. To avoid personal injury and equipment damage, make sure the supply pressure never exceeds the maximum safe working pressure of any connected equipment.

CAUTION

Do not use sealing tape on pneumatic connections. This instrument contains small passages that may become obstructed by detached sealing tape. Thread sealant paste should be used to seal and lubricate pneumatic threaded connections.

To complete the installation of a positioner, connect tubing and fittings between the positioner and the actuator. The fittings, tubing, and mounting parts required depend on the type number and optional equipment such as filter, regulator, and bypass valve.

Positioner pressure and electrical connection locations are shown in figure 12. All pressure connections are 1/4 NPT internal. Use 3/8-inch tubing or 1/4 NPT pipe for all tubing connections.

Figure 12. Connections

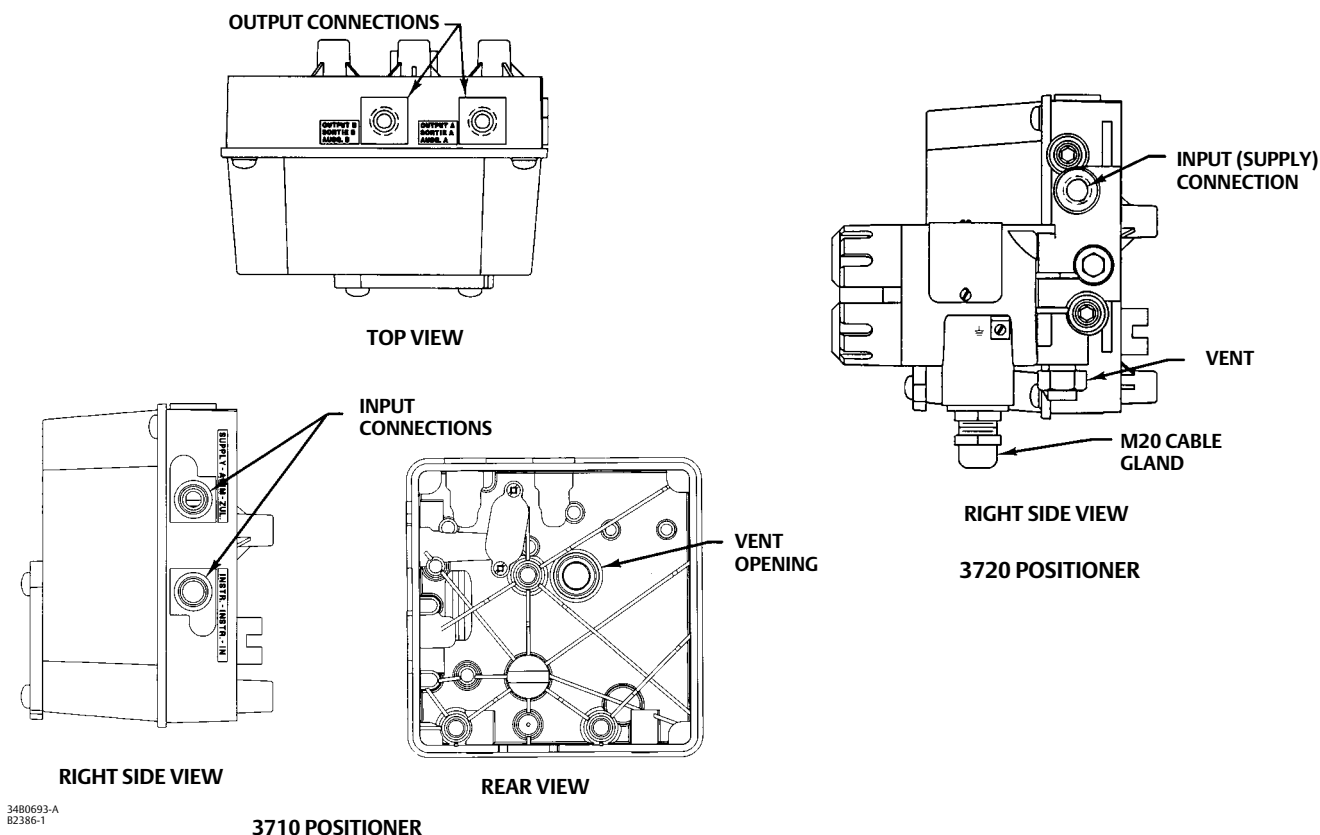

The conduit connection to the converter is 1/2-14 NPT.

The positioner does not have a remote vent connection. Refer to the section on vent opening, purge option, and actuator vent connection for instructions about a remote vent connection.

Supply Connection

⚠ WARNING

Severe personal injury or property damage may occur if the instrument supply medium is not clean, dry and oil-free. While use and regular maintenance of a filter that removes particles larger than 40 micrometers in diameter will suffice in most applications, check with an Emerson field office and industry instrument air quality standards for use with corrosive gas or if you are unsure about the proper amount or method of air filtration or filter maintenance.

3720 positioners and 3722 converters do not meet third party approvals for use with natural gas as the supply pressure medium. Use of natural gas as the supply medium can result in personal injury or property damage from fire or explosion.

See figure 12.

Connect a clean, dry, oil-free, noncorrosive air source to the supply connection of the positioner. Recommended supply line size is 3/8-inch tubing or 1/4 NPT pipe. Use of an appropriate supply air filter or filter regulator is recommended. Refer to the positioner specifications, table 1, for supply pressure requirements.

Supply pressure must not exceed the following limits:

- For the positioner, do not exceed the maximum pressure rating of 10.3 bar (150 psig).
- For actuator pressure, refer to the appropriate actuator instruction manual for maximum allowable pressures.
- For the valve body assembly, do not exceed the maximum allowable torque or thrust of the specific valve.

Output Connections

See figure 12.

Use 3/8-inch tubing between the actuator and positioner.

For diaphragm rotary actuators (single-action output from the positioner): Plug OUTPUT A. Connect OUTPUT B to the diaphragm casing connection.

For piston rotary actuators (double-action output from the positioner): To extend the actuator stem with increasing instrument input signal, connect OUTPUT A to the lower actuator cylinder connection and OUTPUT B to the upper actuator cylinder connection. To retract the actuator stem with increasing instrument input signal, connect OUTPUT A to the upper actuator cylinder connection and OUTPUT B to the lower actuator cylinder connection.

Instrument Connection

See figure 12.

Use 3/8-inch tubing to connect the output from the control device to the INSTRUMENT connection on a pneumatic positioner. For the electro-pneumatic positioner, refer to the Electrical Connection section.

Vent Opening, Purge Option, and Actuator Vent Connection

⚠ WARNING

Personal injury or property damage could result from fire or explosion of the accumulated gas if a flammable gas is used as the supply pressure medium. Personal injury or property damage could also result from contact with the hazardous gas.

The 3710 positioner/actuator assembly does not form a gas-tight seal and flammable or hazardous gas could leak from the assembly. Therefore, if the assembly is enclosed, install a remote vent line from the enclosure. However, a remote vent pipe from the enclosure alone cannot be relied upon to remove all hazardous gas. Use adequate ventilation and other necessary safety measures. Vent line piping should comply with local and regional codes and should be as short as possible with adequate inside diameter and few bends to reduce case pressure buildup.

⚠ WARNING

3720 and 3722 do not meet third party approvals for use with natural gas as the supply pressure medium. Use of natural gas as the supply medium can result in personal injury or property damage from fire or explosion.

See figure 13.

Figure 13. Mounting the Positioner Base Plate with Purge Tube

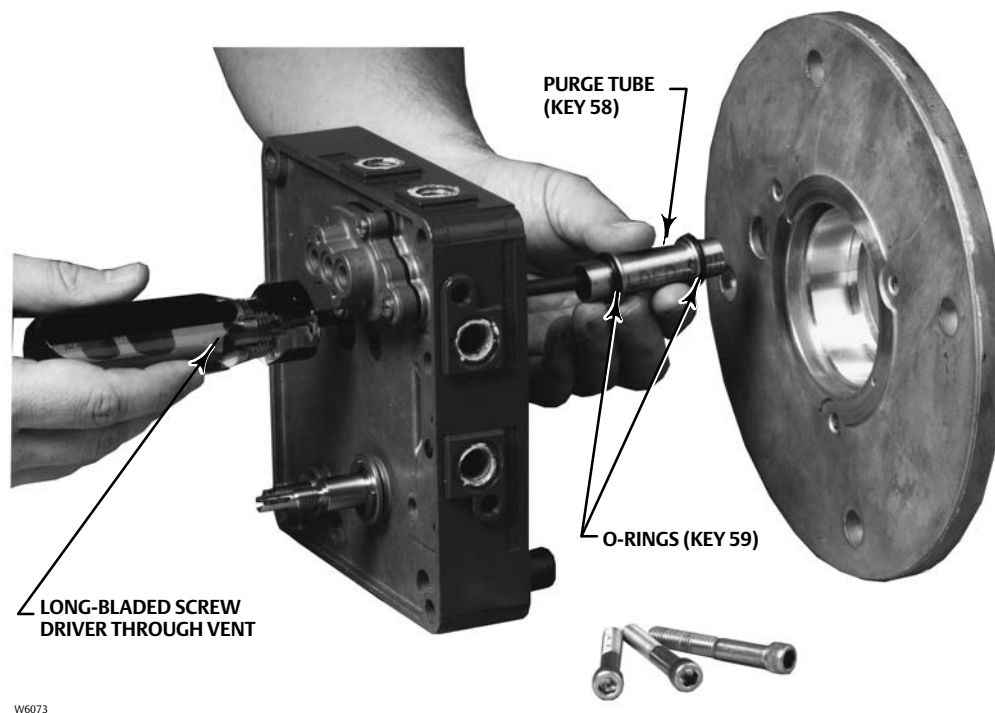

W6073

The positioner does not have an external vent connection. A unit exhausts actuator pressure through a screened hole (vent opening, figure 12) located in the positioner base plate. Do not restrict the vent opening. Restricting the vent opening can produce a pressure buildup in the positioner case and degrade positioner performance.

A purge tube (key 58, figure 13) is available as an option when mounting the positioner on selected Fisher actuators. One end of the purge tube with an O-ring (key 59) installs in the actuator cover plate. The other end of the purge tube with an O-ring installs in the vent opening in the positioner base plate. When the purge tube is used, it relays actuator exhaust pressure from the positioner into the actuator housing.

Within the actuator and positioner assembly, exhaust pressure takes the following course:

- The actuator exhaust pressure vents from the actuator through the positioner spool valve into the positioner case.
- The exhaust pressure then exits the positioner case through the vent opening.
- The purge tube carries the exhaust pressure into the actuator housing.
- The exhaust pressure then purges the actuator housing and dissipates from the housing.

Most Fisher actuators do not have vent openings. The exhaust pressure simply dissipates from within the actuator housing. However, the 1051, 1052, and 1061 actuators feature an operational screened vent connection when a metal access plate is specified for the actuator housing.

When using the purge option, remember: The actuator and positioner assembly is not airtight. However, if you use the optional purge tube to connect the positioner to the actuator and the actuator has a vent opening, leave open the 1/4 NPT vent connection in the actuator housing to prevent pressure buildup in the positioner case.

If the 1/4 NPT vent connection is available, a vent line can be installed from the actuator. However, the valve/actuator/positioner assembly is not airtight. Maintain adequate ventilation and observe other safety measures.

For help in selecting the purge option for positioner/ actuator combinations, contact your [Emerson sales office](#) or Local Business Partner.

Connecting the Purge Tube

The positioner mounts directly to the actuator cover plate of 1051, 1052, and 1061 actuators. See table 4 for actuator sizes.

With an integral mounting, a purge tube (key 58), with two O-rings (key 59), can be used to relay actuator exhaust pressure from the positioner into the actuator housing. If the current actuator cover plate does not have the positioner mounting holes and purge tube knockout, order a new cover plate. See the parts list for the specific actuator cover plate required for each actuator.

1. The actuator cover plate features a purge tube knockout. Locate the knockout and use appropriate tools to open this hole in the cover plate.
2. Install the actuator cover plate and then insert the purge tube with O-ring into the purge tube hole in the cover plate.

Note

When mounting a positioner to an actuator with the purge tube installed, guide the purge tube into the vent opening in the positioner base plate by removing the vent screen (key 41) and then inserting an appropriate tool such as a screwdriver through the vent opening into the purge tube.

When the positioner is secured to the actuator, install the vent screen.

3. Before mounting the positioner, be sure the second O-ring is properly fitted to the end of the purge tube. Use care when mounting the positioner. Be sure the purge tube with O-ring fits into the vent opening on the rear of the positioner base plate.
4. Secure the positioner to the mounting plate using the (hex) socket head cap screws (key 46).
5. Install the vent screen in the positioner base plate.

Electrical Connection for the 3720 Positioner

⚠ WARNING

In explosion-proof applications, disconnect power before removing the converter housing cap.

In Class I, Division 1 explosion-proof applications, install rigid metal conduit and a conduit seal no more than 457 mm (18 inches) from the converter. Personal injury or property damage may result from explosion if the seal is not installed.

For intrinsically-safe installations, refer to the loop schematics included in the appropriate Hazardous Area Approval Supplement (CSA, [D104315X012](#) or FM, [D104316X012](#)) or to instructions provided by the barrier manufacturer for proper wiring and installation.

Select wiring and/or cable glands that are rated for the environment of use (such as hazardous area, ingress protection and temperature). Failure to use properly rated wiring and/or cable glands can result in personal injury or property damage from fire or explosion.

Wiring connections must be in accordance with local, regional, and national codes for any given hazardous area approval. Failure to follow the local, regional, and national codes could result in personal injury or property damage from fire or explosion.

Use the 1/2-14 NPT conduit connection for field wiring installation. Refer to figures 14 and 15 when connecting field wiring from the control device to the converter. Connect the positive wire from the control device to the converter's positive (+) terminal and the negative wire from the control device to the converter's negative (-) terminal.

Do not overtighten the terminal screws. Maximum torque is 0.45 Newton-meters (0.45 N•m) or 4 pounds force per inch (4 lbf•in).

Figure 14. Field Wiring Diagram

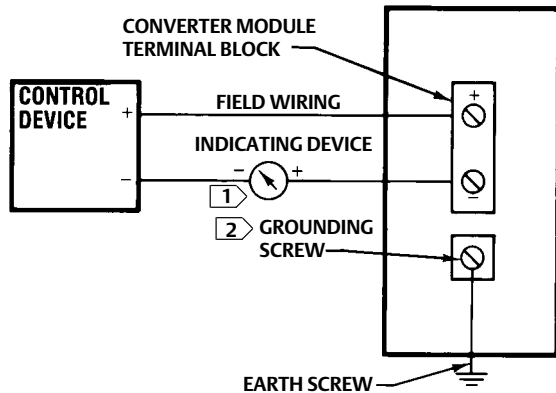

NOTES:

- 1) FOR TROUBLESHOOTING OR MONITORING OPERATION THE INDICATING DEVICE CAN BE A VOLTMETER ACROSS A 250 OHM RESISTOR OR CURRENT METER
 2) THE 3722 CONVERTER HOUSING FEATURES INTERNAL AND EXTERNAL GROUNDING SCREWS

Figure 15. Circuit Schematic

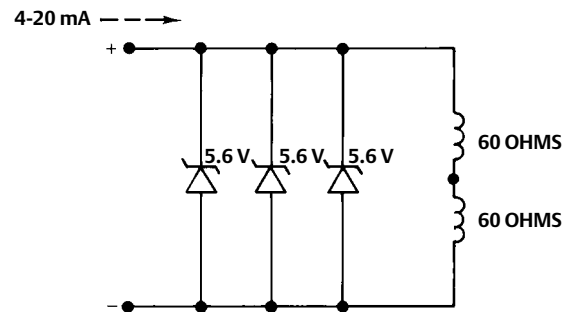

Diagnostic Connections

See figure 16.

For diagnostic testing of control valve packages (valve, actuator, positioner, and accessories), special connectors and hardware are available. The hardware required for diagnostic connections includes 3/4 NPT pipe nipples and pipe tees with a

1/8 NPT pipe bushing for the connector. The connector consists of a 1/8 NPT body and body protector. If the diagnostic connectors are ordered for a positioner with gauges, 1/8-inch stems are also included.

Install connectors and hardware between the positioner and the actuator.

1. Before assembling the pipe nipple, pipe tee, pipe bushing, actuator piping, and connector body, apply sealant (key 64) to all threads.
2. Assemble connectors and hardware. Remove standard piping connections, if necessary, and install the diagnostic connections.
 - **3720:** For a diagnostic connection to the instrument pressure output from the converter module, remove the 1/8 NPT pipe plug (key 86) from the 3722 converter housing. Apply sealant (key 83) to the threads of the 1/8 NPT connector body and install it directly into the housing.
 - **3710, 3720:** For diagnostic connections made up of a pipe nipple, pipe tee, pipe bushing, and connector body, turn the pipe tee to position the connector body for easy access when doing diagnostic testing.

Figure 16. Diagnostic Connections

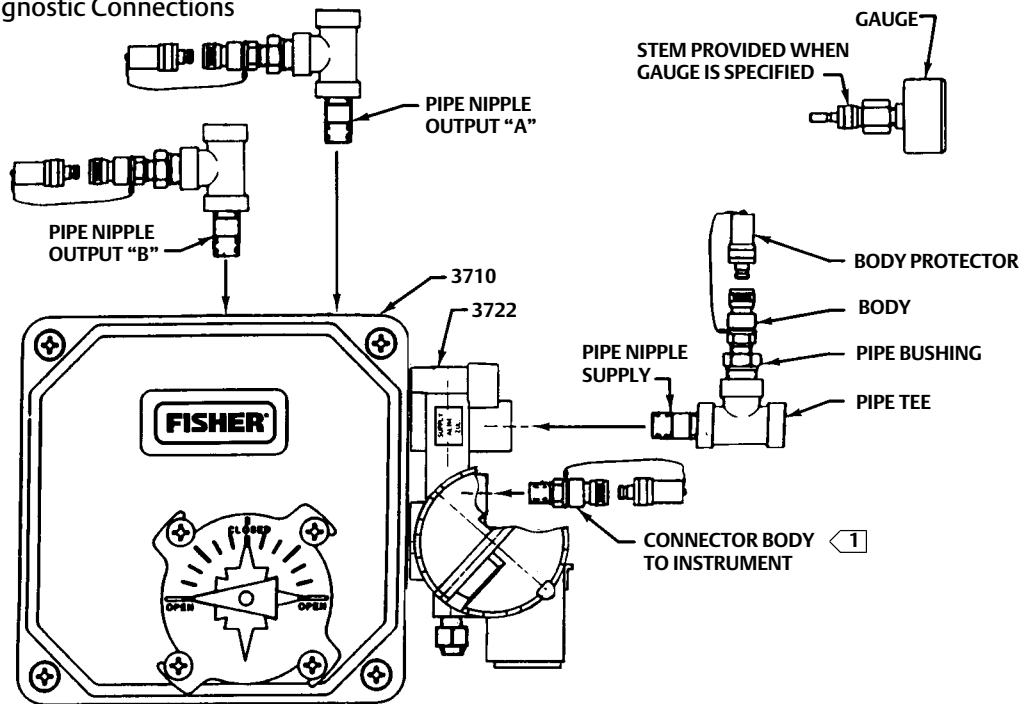

1388743-A
B2414

3720 POSITIONER

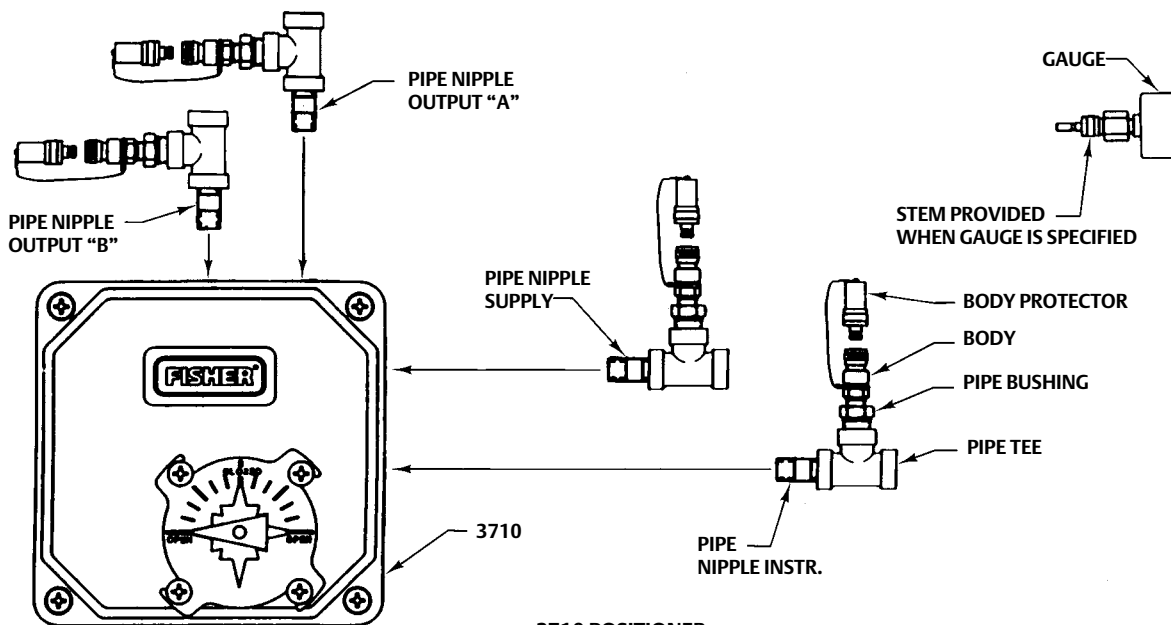

1288055-A
B2385

3710 POSITIONER

Calibration

The following calibration procedures are for the 3710 pneumatic positioner adjustment. For the 3720 electro-pneumatic positioner, there are no adjustments within the 3722 converter portion of the positioner. All adjustments are accomplished within the pneumatic portion of the positioner.

⚠ WARNING

During calibration the valve will move. To avoid personal injury or property damage caused by the release of pressure or process fluid, provide some temporary means of control for the process.

Setting the Initial Cam Position

Before trying any calibration procedure, follow these instructions to position the cam (key 36) with respect to the valve position.

1. Unscrew the four captive cover screws (key 8) and remove the positioner cover assembly (key 7).
2. See figure 17. Inspect the cam (key 36) and loosen the cam locknut (key 37).
3. Disconnect the positioner output tubing at the actuator and attach a regulated air source or other means of positioning the actuator.
4. Position the actuator to correspond with the initial valve position at minimum instrument input signal. Stroke the actuator to the final valve position and note the direction of actuator shaft rotation. Return the actuator to its initial valve position.
5. See figure 18. Position the cam on the roller for the desired input signal range, for example, 0-100%, and insure that the arrow on the cam corresponds with the direction of actuator shaft rotation for increasing input signal. Tighten the cam locknut, leaving a gap of approximately 0.80 mm (0.031 inches) between the cam and roller. Tighten the cam nut to 3.8 to 9.1 n•m (30 to 75 lbf•in).
6. Reconnect the output tubing to the actuator.

Figure 17. Loosening the Cam Locknut

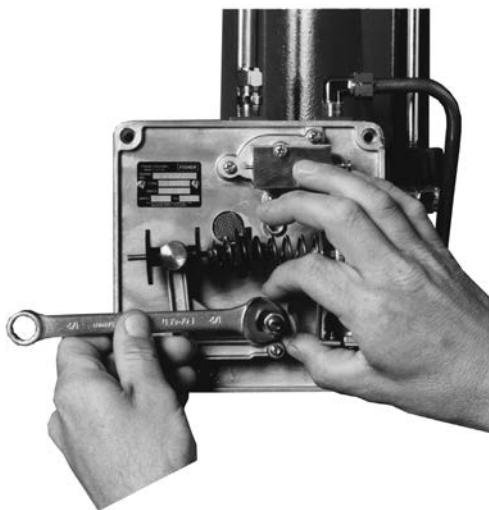

W5916

Figure 18. Proper Cam Position

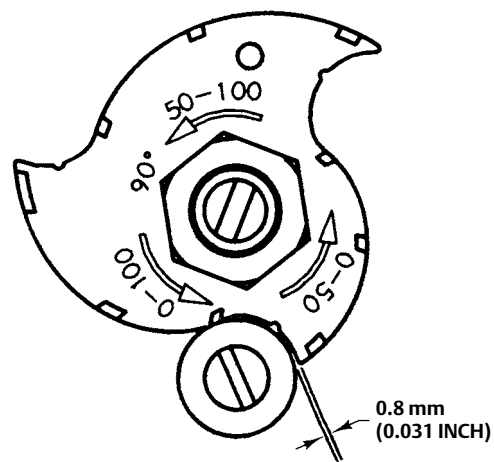

A6045

Zero and Span Adjustments

See figure 19.

Figure 19. Features and Adjustments

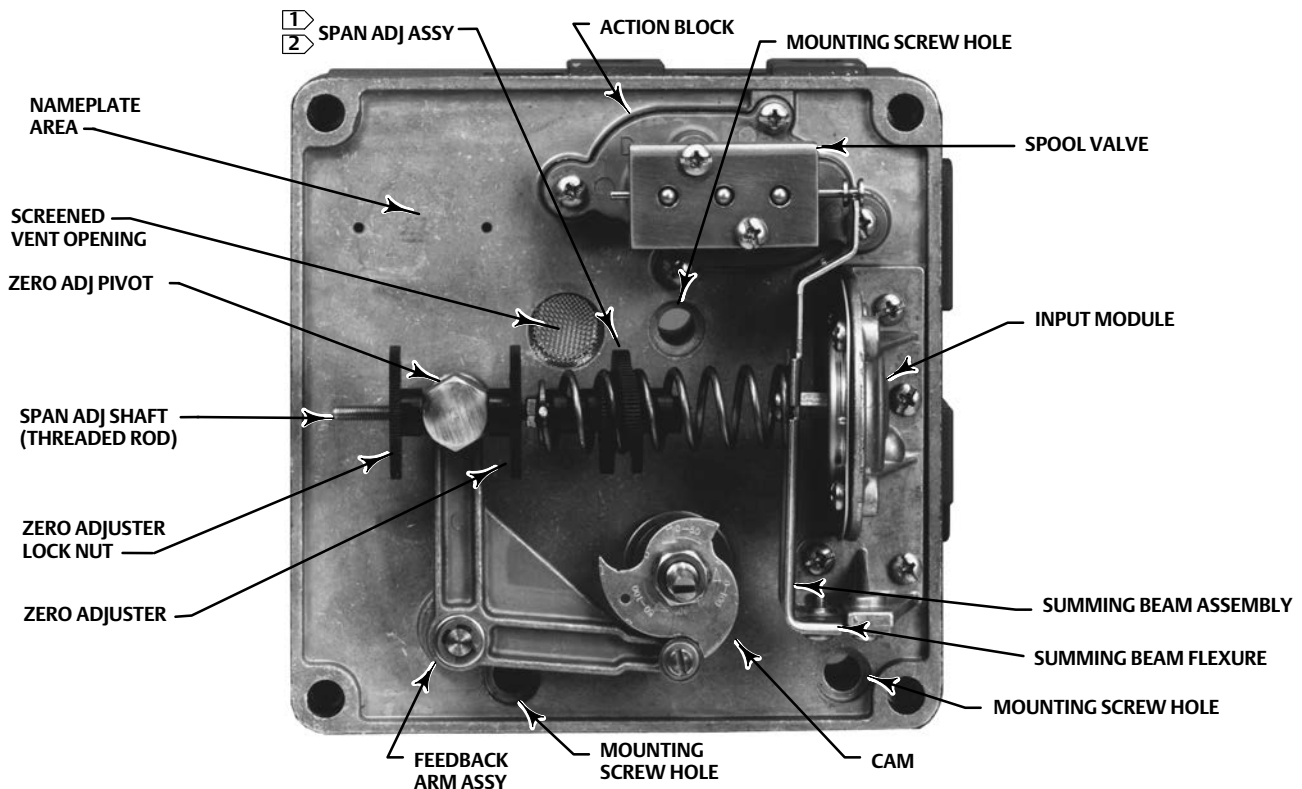

NOTES:

- 1 THE SPAN ADJ ASSY IS MADE UP OF THE RANGE SPRING, SPAN ADJ SHAFT (THREADED ROD), AND SPAN ADJ KNOB.
- 2 THE SPAN ADJ ASSY FEATURES A RED COLOR-CODED RANGE SPRING FOR A 0.4 TO 2.0 BAR (6 TO 30 PSIG) INPUT SIGNAL.

W5947

1. To start this procedure, if necessary, unscrew the four captive cover screws (key 8) and remove the cover assembly (key 7).
2. Apply supply pressure.
3. Provide a way to check the input signal. Apply the minimum input signal. For example:
 - For a 3710 pneumatic positioner, if the input signal range is 0.2 to 1.0 bar (3 to 15 psig), apply 0.2 bar (3 psig).
 - For a 3720 electro-pneumatic positioner, if the input signal range is 4-20 mA, apply 4 mA to the 3722 converter.

Note

The zero adjustment locknut and zero adjustment knob are identical parts, key 35.

4. Loosen the zero adjustment locknut (key 35) and turn the zero adjustment knob (key 35) until the actuator moves the valve to the proper position. This valve position must correspond to the minimum input signal.

Tighten the zero adjustment locknut before proceeding to step 5.

5. Slowly increase the input signal until the input reaches the maximum input signal. Observe the actuator travel and valve position as the input increases. Determine the actuator/valve position at the maximum input signal.
6. After observing the actuator/valve travel at maximum input signal, return the input signal to the minimum input signal before turning the span adjustment knob.
 - If the actuator/valve travel, observed in step 5, **stopped short** of the required valve position at maximum input signal, increase the actuator/valve travel by rotating the positioner span adjustment knob toward the zero adjustment nut (key 35) to add active spring coils to the range spring.
 - If the actuator/valve travel, observed in step 5, reaches the required valve position **before** the input signal reaches the maximum input signal, decrease the actuator/valve travel by rotating the positioner span adjustment knob away from the zero adjustment nut (key 35) to remove active spring coils from the range spring.
7. After turning the span adjustment knob to change actuator travel, re-zero the positioner using the procedure given in steps 4 and 5, above.

Note

The outputs of a properly calibrated positioner will be in the saturated condition (zero pressure or full supply) when the valve is fully open or closed.

8. Increase the input signal until the input reaches the maximum input signal. Observe the actuator/valve travel as the input increases.
- Repeat steps 3 through 8 until the actuator travel corresponds to the input signal range.
9. Properly align the indicator and replace the positioner cover assembly.

Standard or Beacon Indicator Alignment

Note

The standard, low-profile indicator consists of the indicator cover (key 14), indicator (key 15) with internal retaining ring (e-clip) (key 12), and separate pointer (key 13) recessed into the indicator. An O-ring (key 15A) fits over the molded screwdriver slot in the indicator to retain the pointer.

The optional beacon indicator consists of an external unit (key 10) with external retaining ring (key 12) and extension shaft (key 11).

See figure 20.

1. Locate the indicator/extension shaft (key 11 or key 15) inside the front cover. To align the indicator, rotate the indicator/extension shaft to match the position of the feedback shaft extending from the cam (key 36).
2. Install the cover assembly (key 7) so that the indicator/extension shaft joins with the feedback shaft. The standard indicator (key 15) features a molded screwdriver slot that protrudes through the indicator cover (key 14). If necessary, use a small, Phillips head screwdriver to align the indicator with the feedback shaft.

Figure 20. Standard Indicator

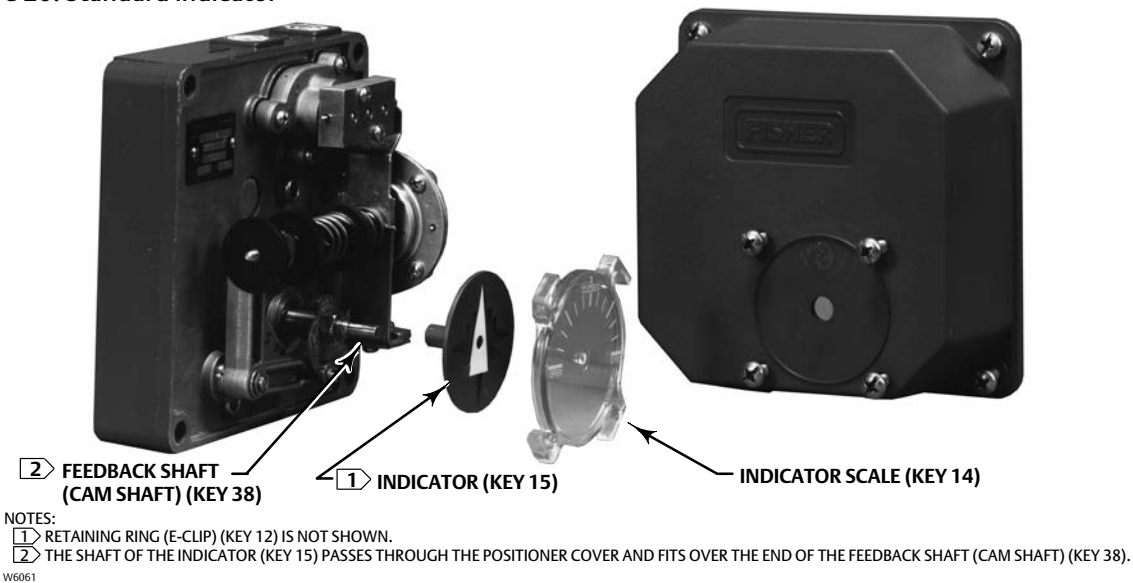

3. Inspect the indicator, pointer, and scale. Make sure the proper valve position is shown. Follow the procedures given in this instruction manual to move the valve from fully opened to fully closed. Make sure the indicator properly displays the valve position.

If the indicator is not properly aligned, continue with the following procedure.

4. If the indicator pointer and indicator scale are slightly out of alignment, loosen the four machine screws (key 3) that hold the indicator scale to the positioner cover. Turn the scale to properly align it with the pointer. Tighten the four screws and move the valve to confirm proper valve position indication.
5. If the pointer in the standard, low-profile indicator is positioned in the wrong quadrant, loosen the four machine screws (key 8) that hold the indicator scale (key 14) to the positioner cover. Remove the indicator scale. Then, carefully lift the pointer (key 13) from the indicator (key 15). Place the pointer in the proper position and re-install the indicator scale, and screws. Make sure the indicator scale and pointer are now properly aligned by moving the valve. If sufficient adjustment is not available in the scale, the actuator might be installed incorrectly.
6. If the internal scale of the beacon indicator is not properly aligned, remove the four machine screws that hold the beacon indicator (key 10) to the positioner cover. Properly orient the beacon cover and replace the screws. Make sure the beacon cover and scale are now properly aligned by moving the valve.

Changing Positioner Action

⚠ WARNING

Avoid personal injury or equipment damage from sudden release of process fluid. Before changing positioner action:

- Wear protective eyewear, gloves, and clothing whenever possible.
- Do not remove the actuator from the valve while the valve is still pressurized.
- Disconnect any operating lines providing air pressure, electric power, or a control signal to the actuator and accessories. Be sure the actuator cannot suddenly open or close the valve.
- Use bypass valves or completely shut off the process to isolate the valve from process pressure. Relieve process pressure on both sides of the valve.

- Vent the actuator loading pressure.
- Use lock-out procedures to be sure that the above measures stay in effect while you work on the equipment.
- Check with your process or safety engineer for any additional measures that must be taken to prevent against process media.

Single-Acting/Double-Acting

See figure 21 for positioner output connections. See figure 23 for the positioner schematic.

Figure 21. Output Connections

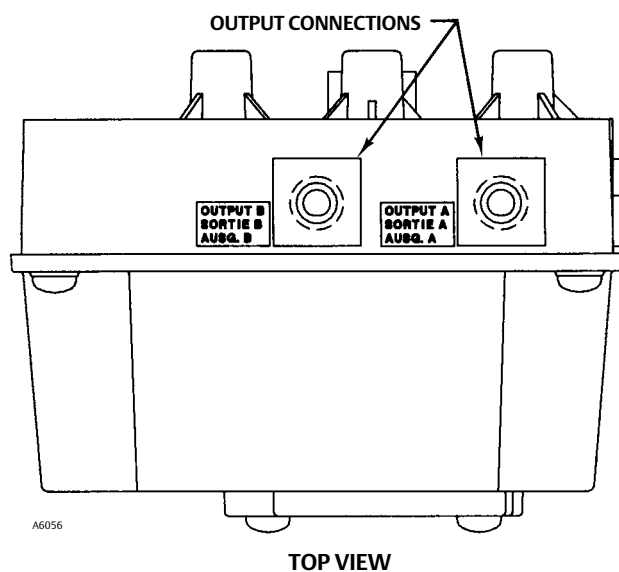

Use 3/8-inch tubing between the positioner and actuator.

- For single-acting output, plug positioner OUTPUT A. Refer to the actuator instruction manual for the specific connection for positioner OUTPUT B. Connect positioner OUTPUT B to the actuator connection for single-acting. For Fisher diaphragm actuators, this connection is known as the diaphragm casing connection.
- For double-acting output (with direct-action), refer to the actuator instruction manual for the specific connections for positioner OUTPUT A and B. Connect positioner OUTPUT A to the actuator cylinder connection where actuator air pressure is exhausted during the initial actuator stroke. Connect positioner OUTPUT B to the actuator cylinder connection where supply pressure enters the actuator during the initial actuator stroke. For Fisher piston actuators, OUTPUT A connects to the lower actuator cylinder connection and OUTPUT B connects to the upper actuator cylinder connection.

Direct-Acting/Reverse-Acting

This section explains changing the positioner action from direct to reverse or reverse to direct. With direct-action, the actuator stem extends as the input signal to the positioner increases. With reverse-action, the actuator stem retracts as the input signal to the positioner increases.

See figure 21.

1. Turn off supply pressure. Reverse the piping connections between the actuator and the positioner output connections (OUTPUT A and OUTPUT B).
 - For single-acting output, disconnect piping from OUTPUT B. Unplug OUTPUT A and connect the piping to it. Plug OUTPUT B.
 - For double-acting output, disconnect piping from both positioner outputs. Connect piping from OUTPUT A to OUTPUT B. Connect piping from OUTPUT B to OUTPUT A.

It may be necessary to bend new lengths of tubing if rigid tubing is used.

2. After reversing the piping connections, remove the positioner cover assembly (key 7) and reverse the cam (key 36). To reverse the cam, unscrew the cam locknut (key 37). Remove the cam, turn it over, and reinstall it, making sure the cam is positioned for the proper input signal range.
3. Set the initial cam position following the cam alignment procedure given in this manual. Tighten the cam locknut.
4. Turn on supply pressure. Perform the zero and span adjustment procedure given in this manual.
5. Replace the positioner cover assembly.

Split-Range Operation

The positioner can be used for split-range operation with the input signal from a single control device split between two positioner/actuator/control valve packages. One positioner will fully stroke one actuator with an input signal range from:

- 0.2 to 0.6 bar (3 to 9 psig)
- 0.6 to 1.0 bar (9 to 15 psig)
- 0.4 to 1.2 bar (6 to 18 psig)
- 1.2 to 2.0 bar (18 to 30 psig)

1. Turn off supply pressure. Remove the positioner cover assembly (key 7).
2. Loosen the cam locknut (key 37). Rotate the cam to the desired split-range value: either “0-50%” or “50-100%”.
3. Before tightening the cam locknut, perform the cam alignment procedure given in this manual.
4. Turn on supply pressure. Perform the zero and span adjustment procedure given in this manual. Use the proper input signal range to match the cam split-range value selected in step 2, above.
5. Replace the positioner cover assembly.

Changing the Spool Valve

⚠ WARNING

Avoid personal injury or equipment damage from sudden release of process fluid. Before changing the spool valve:

- **Wear protective eyewear, gloves, and clothing whenever possible.**
- **Do not remove the actuator from the valve while the valve is still pressurized.**
- **Disconnect any operating lines providing air pressure, electric power, or a control signal to the actuator and accessories. Be sure the actuator cannot suddenly open or close the valve.**
- **Use bypass valves or completely shut off the process to isolate the valve from process pressure. Relieve process pressure on both sides of the valve.**

- **Vent the actuator loading pressure.**
 - **Use lock-out procedures to be sure that the above measures stay in effect while you work on the equipment.**
 - **Check with your process or safety engineer for any additional measures that must be taken to prevent against process media.**
-

1. Turn off supply pressure. Release actuator pressure. Remove the positioner cover assembly (key 7).
-

Note

Handle the spool valve body and spool with care. The body and spool are manufactured to precise tolerances and are prepared as a matched set.

2. Unscrew the two machine screws (key 3) that hold the spool valve (key 1) onto the action block (key 28). Remove the spool valve, taking care when separating the spool from the spool flexure on the summing beam.
 3. Inspect the three O-rings (key 2) found between the spool valve and the action block. Remove and replace the O-rings, if necessary.
-

Note

Handle the spool valve body and spool with care. The body and spool are manufactured to precise tolerances and are prepared as a matched set.

4. Check the function of the new spool valve to be installed. The spool should slide freely in the valve body.
-

Note

See figure 22. Before securing the spool valve, make sure the spool head makes proper contact with the end of the summing beam.

5. See figure 22. Position the spool valve on the action block. Make sure the spool extending from the spool valve body properly engages the summing beam. Start the two machine screws (key 3) so the spool valve is loosely held in position on the action block.
6. **Before tightening the machine screws holding the spool valve, make sure the end of the summing beam does not contact the spool.** Rather, the summing beam should contact the **spool head**. If necessary, adjust the position of the spool valve on top of the action block, making sure the summing beam does not bind on the spool throughout the full travel of the summing beam. Tighten the two machine screws.
7. Be sure the spool head and summing beam remain engaged, but do not bind up, over the entire operating range of the input module.

Figure 22. Spool Valve and Summing Beam

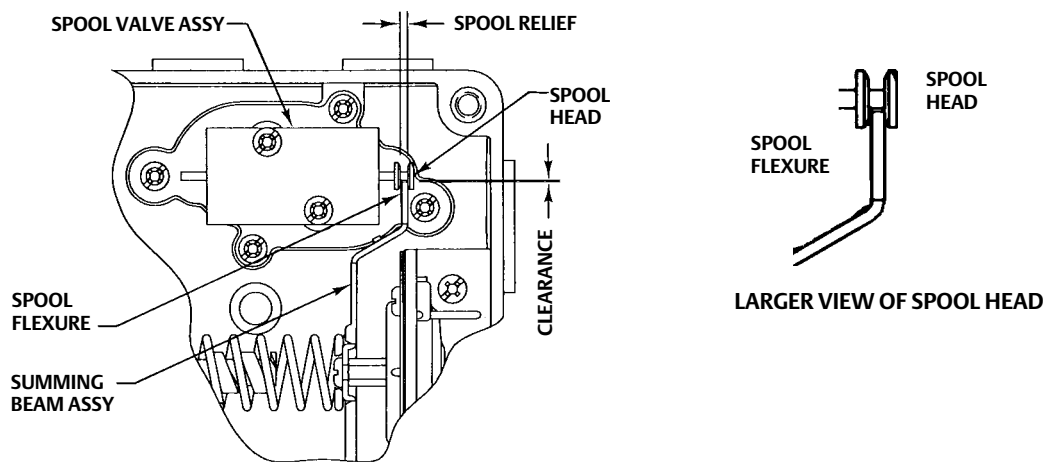

A6044

Changing the Span Adjuster Assembly (To Change Positioner Input Range)

The span adjuster assembly (key 4) consists of the span adjustment knob, span adjustment shaft (threaded rod), range spring, and washer. The range spring is welded to the washer and the washer is welded to the span adjustment shaft.

To identify the span adjuster assembly for 0.4 to 2.0 bar (6 to 30 psig) input range, red color coding appears on the range spring.

1. Unscrew the cam locknut (key 37) and remove the cam (key 36).

Note

The zero adjustment locknut and zero adjustment knob are identical parts, key 35.

2. Loosen the zero adjustment locknut and turn the zero adjustment knob (key 35) until the range spring is free from the summing beam. Move the feedback arm (key 21) until the range spring falls away from the summing beam.

Note

The feedback pivot cannot be removed from the positioner base plate.

3. Remove the retaining ring (e-clip) (key 27) which holds the feedback arm assembly (key 21) onto the feedback pivot. Remove the washer under the retaining ring and pull the feedback arm from the pivot.
4. Remove the span adjuster assembly from the feedback arm by removing the zero adjuster locknut and sliding the span adjustment shaft (threaded rod) from the zero adjustment pivot on the feedback arm.
5. Remove the zero adjustment knob from the span adjuster assembly. Install the zero adjustment knob on the new span adjuster assembly.

6. Inspect the zero adjustment pivot (key 32). Be sure it rotates freely. If necessary, replace the zero adjustment pivot. Also, if necessary, replace the feedback arm assembly (key 21) and cam roller (key 23), following the instructions given in this manual.
7. Install the new span adjuster assembly by sliding the span adjustment shaft (threaded rod) through the zero adjustment pivot. Install the zero adjustment locknut on the span adjustment shaft.
8. Install the feedback arm assembly with the new span adjuster assembly by returning the feedback arm assembly to the feedback pivot. Turn the zero adjustment locknut and zero adjustment knob as needed to fit the range spring to the summing beam. Install the washer and retaining ring that hold the feedback arm assembly in position.
9. Install the cam and cam locknut. Be sure the cam roller on the feedback arm assembly is properly positioned in contact with the cam.
10. Perform the calibration procedures in this manual.

Principle of Operation

See figure 23.

Figure 23. Fisher 3710 Positioner Schematic

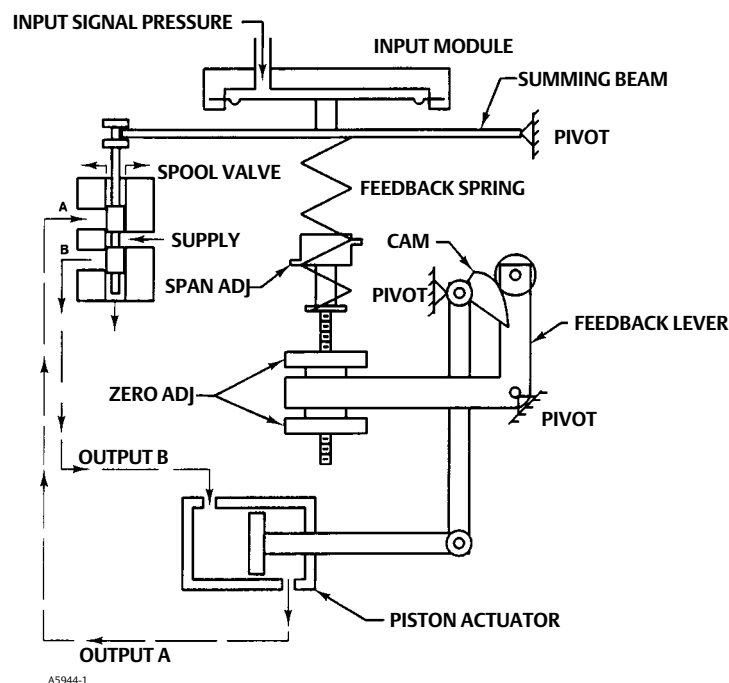

The 3710 pneumatic positioner accepts a pneumatic input signal and the 3720 electro-pneumatic positioner accepts a milliampere (mA), direct current (DC), input signal from a control device. The 3720 positioner uses a 3722 converter to provide a pneumatic input to the pneumatic portion (3710) of the electro-pneumatic positioner.

The pneumatic portion of the positioner is a force-balance instrument that provides a control valve position proportional to a pneumatic input signal. The balance of opposing forces in the positioner occurs at the summing beam.

One force applied to the summing beam is developed from the input signal pressure on the diaphragm. The other force is from the range spring and is proportional to the position of the feedback lever. The feedback lever position is

determined by the location or rise of the cam which is attached to the feedback shaft. When the two opposing forces are equal or at a steady state, the summing beam holds the spool in a neutral position. At steady state, a small flow of air passes from supply through both outputs of the spool valve to the actuator, holding the actuator at a constant position. At the same time, another small flow of air exhausts out each end of the spool valve.

When the input pressure is increased to the diaphragm of the input module, the diaphragm strokes down, increasing the effective force from the input module and compressing the range spring. The summing beam moves the spool down in the spool body, opening output port B to supply air to the left side of the actuator. At the same time, output port A of the spool valve opens, allowing the right side of the actuator to vent to atmosphere.

The piston in the actuator moves to the right, rotating the feedback shaft and cam counterclockwise. This rotation causes the feedback lever to rotate clockwise, increasing the compression on the range spring. These rotations continue until the additional force from the spring balances with the input module force on the summing beam. When the forces are equal, the summing beam returns to its steady state or neutral position and the actuator is held at a new position.

Maintenance

Parts are subject to normal wear and must be inspected and replaced as necessary. The frequency of inspection and replacement depends upon the severity of service conditions. The following procedure describes disassembly and reassembly of the positioner. When inspection or repairs are required, disassemble only those parts necessary to accomplish the task. When reassembly is complete, adjust the positioner as described in the Calibration section of this manual.

⚠ WARNING

Avoid personal injury or equipment damage from sudden release of process fluid. Before performing any positioner maintenance:

- **Wear protective eyewear, gloves and clothing whenever possible when performing any maintenance operation.**
- **Do not remove the actuator from the valve while the valve is still pressurized.**
- **Disconnect any operating lines providing air pressure, electric power, or a control signal to the actuator and accessories. Be sure the actuator cannot suddenly open or close the valve.**
- **Use bypass valves or completely shut off the process to isolate the valve from process pressure. Relieve process pressure on both sides of the valve.**
- **Vent the actuator loading pressure.**
- **Use lock-out procedures to be sure that the above measures stay in effect while you work on the equipment.**
- **Check with your process or safety engineer for any additional measures that must be taken to protect against process media.**

Positioner Maintenance

Replacing the Standard or Beacon Indicator

1. Remove the positioner cover assembly (key 7).
2. Remove the four machine screws (key 8) that hold the indicator scale (key 14) to the positioner cover. Remove any other external indicator parts such as the pointer (key 13).

Note

The standard, low-profile indicator uses a retaining ring (e-clip) (key 12) inside the positioner cover. The retaining ring holds the indicator. After removing the external scale, remove the internal retaining ring to free the indicator.

The optional beacon indicator uses a retaining ring (e-clip) (key 12) on the outside of the positioner cover. The retaining ring holds the extension shaft. After removing the beacon indicator, remove the external retaining ring to free the extension shaft.

3. Remove the internal or external retaining ring that holds the indicator/extension shaft. Remove the indicator/extension shaft from the positioner cover.
4. Install the new indicator/extension shaft and secure it with the retaining ring. Install other indicator parts and properly align the indicator using the procedure given in this instruction manual.

Removing the 3722 Converter

See figure 24.

Figure 24. Removing the Converter Mounting Screws



W6149

REMOVING ONE OF THE TWO MOUNTING SCREWS



W6148

SEPARATING THE CONVERTER FROM THE POSITIONER BASE PLATE

1. Be sure all safety procedures have been followed. Remove the input wiring and supply connection from the installed 3722 housing.
2. Remove the two mounting screws (key 84) and carefully separate the converter from the positioner base plate. Locate the two O-rings (key 85) and inspect them. Save or replace as necessary.
3. Be sure the input and supply ports in the positioner base plate are clean. Apply sealant (key 64) to the threads of any pipe nipples or other connectors to be installed in the ports in the positioner base plate. Connect pneumatic input and supply pressure to the positioner, if necessary.

Removing the Positioner

1. If you are planning to remove a 3720 positioner, be sure to turn off electric power to the 3722 converter. Disconnect field wiring. Release all pressure to the positioner. Disconnect the supply, instrument, and output tubing.
2. Unscrew the four captive cover screws (key 8) and remove the positioner cover assembly (key 7).
3. Unscrew the three socket head screws (key 46) and remove the positioner.

4. Inspect the feedback tie bar (key 42) attached to the actuator hub. If necessary, unscrew the machine screws (key 47) and remove the tie bar.

Removing the Feedback Arm Assembly

1. Unscrew the cam locknut (key 37) and remove the cam (key 36).
-

Note

The zero adjustment locknut and zero adjustment knob are identical parts, key 35.

2. Loosen the zero adjustment locknut and turn the zero adjustment knob (key 35) until the range spring is free from the summing beam. See figure 25. Move the feedback arm (key 21) until the range spring falls away from the summing beam.
-

Note

The feedback pivot cannot be removed from the positioner base plate.

Figure 25. Cam Removed; Range Spring Free From Summing Beam

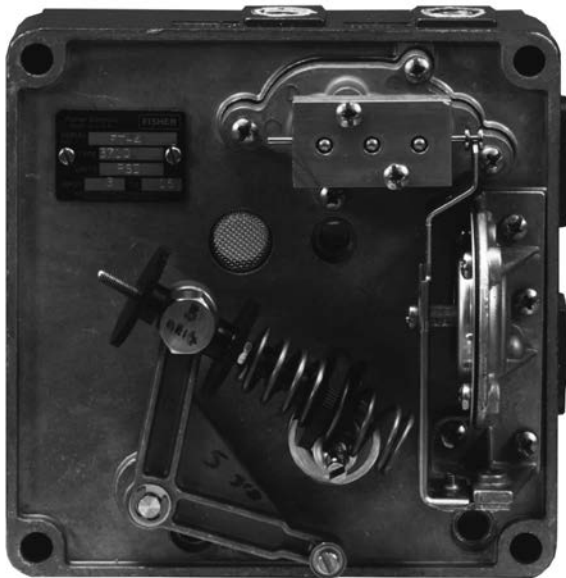

W6062

3. Remove the retaining ring (E-clip) (key 27) which holds the feedback arm (key 21) onto the feedback pivot. Remove the washer under the retaining ring and pull the feedback arm from the pivot.
4. Remove the flanged bearing (key 22) from the feedback pivot or from the feedback arm. Inspect and replace the bearing, if necessary.

Disassembling the Feedback Arm Assembly and Span Adjuster Assembly

Note

The zero adjustment locknut and zero adjustment knob are identical parts, key 35.

Note

To identify the span adjuster assembly for 0.4 to 2.0 bar (6 to 30 psig) input range, red color coding appears on the range spring.

1. Remove the feedback arm assembly and flanged bearing (key 22) from the feedback pivot in the positioner base plate. Then, remove the span adjuster assembly (key 4) by unscrewing the zero adjuster locknut (key 35) and sliding the span adjustment shaft (threaded rod) from the zero adjustment pivot on the feedback arm (key 21).
2. Inspect the flanged bearing. If the bearing shows signs of wear or damage, replace it.
3. Inspect the zero adjustment pivot. Be sure the pivot rotates freely. If necessary, remove the retaining ring (e-clip) (key 34), washer (key 33), and zero adjustment pivot (key 32).
4. After removing the retaining ring, washer, and pivot, inspect the needle bearing (key 25). The needle bearing is pressed into the feedback arm. If the needle bearing must be replaced, replace the feedback arm assembly (key 21).
5. If necessary, replace the retaining ring, washer, and zero adjustment pivot.
6. Be sure the cam roller (key 23) turns freely. If necessary, remove the shoulder screw (key 24) and cam roller from the feedback arm and replace them.

Removing the Feedback Shaft (Cam Shaft)

1. Unscrew the cam locknut (key 37) and remove the cam (key 36).
2. Remove the retaining ring (e-clip) (key 40) and washer (key 39) that hold the feedback shaft (key 38) in place.
3. Grasp the feedback shaft where it extends from the back of the positioner base plate. Pull the feedback shaft from the base plate, being careful not to scratch the outside diameter of the shaft.
4. Inspect the spacer (key 69) on the shaft. Inspect the flanged bearings (key 17) in the positioner base plate. If the spacer or bearings show signs of wear or damage, replace them. When re-installing the feedback shaft, spacer, and bearings, be sure the shaft rotates freely.

Disassembling the Spool Valve, Action Block, and Gasket

Note

See figure 26. Handle the spool valve body and spool with care. The body and spool are manufactured to precise tolerances and are prepared as a matched set.

Figure 26. Spool Valve Body and Spool

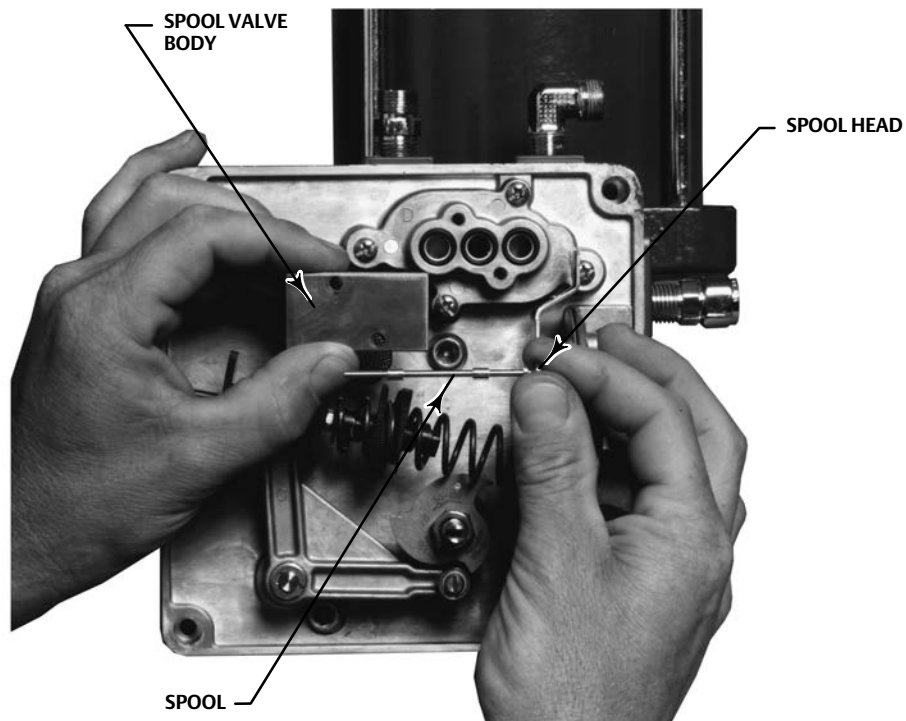

1. Unscrew the two machine screws (key 3) that hold the spool valve (key 1) onto the action block (key 28). Remove the spool valve, taking care when separating the spool from the flexure on the summing beam.
2. Inspect the three O-rings (key 2) found between the spool valve and the action block. Remove and replace the O-rings, if necessary. Lubricate (key 63) O-rings before installation.
3. Unscrew the four machine screws (key 3) that hold the action block onto the positioner base plate. Lift off the action block and inspect the gasket (key 29) underneath it. Replace the gasket, if necessary.
4. Check the function of the spool valve. The spool should slide freely in the valve body. If it doesn't, clean the spool valve or replace it.

Disassembling the Input Module and Summing Beam Assembly

1. Remove the four machine screws (key 3) that hold the input module assembly (key 30) to the positioner base plate. If the spool valve has not been removed, use care when lifting off the input module and summing beam assembly. Be sure to properly separate the spool from the spool flexure.
2. Inspect the one O-ring (key 31) in the positioner base plate. Replace it, if necessary.

CAUTION

Avoid damage to the diaphragm (key 30B) when removing the machine screw (key 30E) that joins the diaphragm connector and the summing beam assembly. Use a wrench or other tool to hold the diaphragm connector while removing the machine screw.

3. Remove the machine screw (key 30E) holding the diaphragm connector to the summing beam assembly, taking care not to twist the diaphragm connector and diaphragm. Use a wrench or other tool to hold the diaphragm connector while removing the machine screw.

4. See figure 27. Separate the summing beam assembly from the input module by removing one of the two machine screws (key 20) that hold the flexure retainers which join the summing beam flexure to the input module housing.

Figure 27. Separating the Summing Beam Assembly from the Input Module

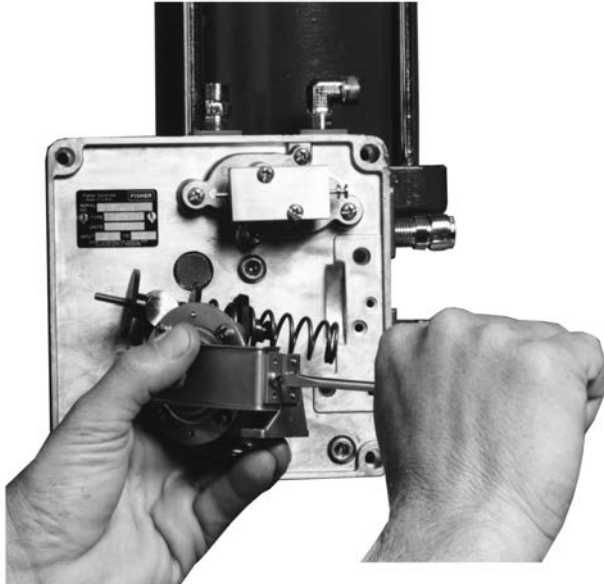

W5913

Replacing the Input Module Diaphragm

See figure 28.

1. After removing the input module, remove the four machine screws (key 20) that hold the input module housing together. Remove the diaphragm cover.
 - Note the orientation of the diaphragm (key 30B) inside the input module.
 - Note the raised center circular area (convolution) of the diaphragm.
 - Note the orientation of the diaphragm plates. The diaphragm plates support the diaphragm and act as travel stops. When assembling the input module, be sure the diaphragm plates are properly positioned.
 - Pull out the assembly (diaphragm, diaphragm plates, and diaphragm connector).
2. Grasp the diaphragm connector with a wrench or other appropriate tool and unscrew the machine screw (key 30F) on the opposite side of the diaphragm. Remove the diaphragm plates and discard the diaphragm.
3. See figure 29. Position the new diaphragm (key 30B) between the diaphragm plates (key 30C). Be sure the diaphragm convolution is properly oriented between the diaphragm plates. Attach the diaphragm connector (key 30D) with the machine screw (key 30F).
4. Position the diaphragm assembly inside the input module housing using the alignment pins. Replace the diaphragm cover and secure it to the input module housing with the four machine screws (key 20).

Figure 28. Input Module Diaphragm and Diaphragm Housing

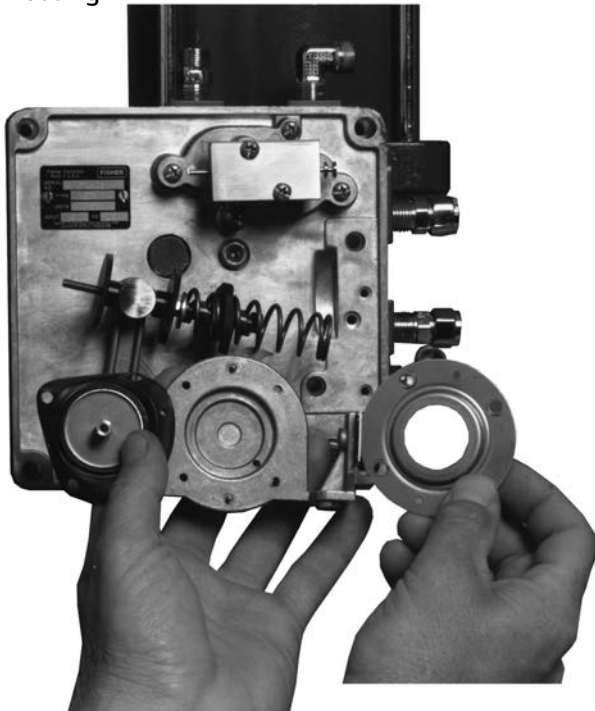

W5915

Figure 29. Assembly of Input Module

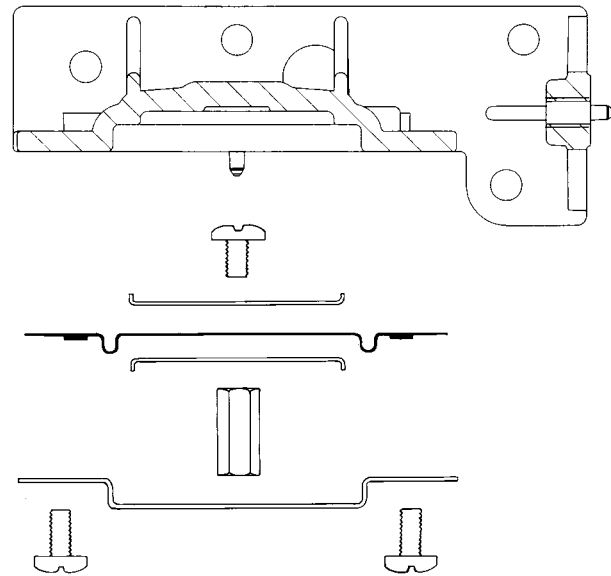

A6043

Assembling the Input Module and Summing Beam Assembly

1. Position the summing beam on the input module housing. Place the flexure over the alignment pins extending from the summing beam and input module. Secure the flexure by placing the two flexure retainers over the alignment pins extending through the flexure. Install the two machine screws (key 20) that hold the flexure retainers.

CAUTION

Avoid damage to the diaphragm (key 30B) when installing the machine screw (key 30E) that holds the diaphragm connector to the summing beam assembly. Use a wrench or other tool to hold the diaphragm connector while installing the machine screw.

2. Install the machine screw (key 30E) that connects the summing beam assembly to the diaphragm connector, taking care not to twist the diaphragm connector and diaphragm (key 30B). Use a wrench or other tool to hold the diaphragm connector while installing the machine screw.
3. Inspect the one O-ring (key 31) in the positioner base plate. Replace it, if necessary. Properly lubricate (key 63) the O-ring.

Note

See figure 30. Before securing the input module and summing beam assembly, make sure the end of the summing beam does not come in contact with the spool shaft. Instead, the end of the summing beam should engage the spool head.

- See figure 30. Properly position the input module and summing beam assembly on the positioner base plate using the alignment pins on the input module. If the spool valve (key 1) has not been removed, use care when positioning the input module and summing beam assembly. Make sure the spool extending from the spool valve body properly engages the spool flexure.

Figure 30. Spool Valve and Summing Beam

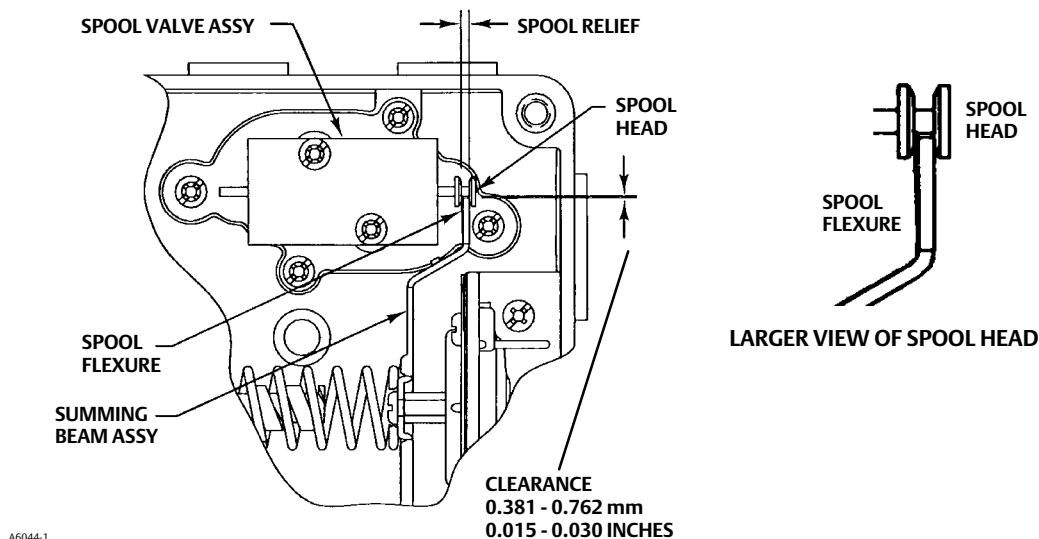

A6044-1

- Secure the assembly with the four machine screws (key 3).

Assembling the Spool Valve, Action Block, and Gasket

- Place the action block gasket (key 29) on the mounting area found on the positioner base plate. Place the action block (key 28) on the gasket and secure it to the base plate using the four machine screws (key 3).
- Inspect the three O-rings (key 2) found between the spool valve (key 1) and the action block. Replace the O-rings, if necessary.

Note

See figure 26. Handle the spool valve body and spool with care. The body and spool are manufactured to precise tolerances and are prepared as a matched set.

- Be sure the spool valve is ready for service. Clean or replace it, if necessary.

Note

See figure 30. Before securing the spool valve, make sure the spool head makes proper contact with the end of the summing beam.

- See figure 30. Position the spool valve on the action block. Make sure the spool extending from the spool valve body properly engages the summing beam. Start the two machine screws (key 3) so the spool valve is loosely held in position on the action block.

5. Before tightening the machine screws holding the spool valve, make sure the end of the summing beam does not contact the spool. Rather, the summing beam should contact the spool head. If necessary, adjust the position of the spool valve on top of the action block, making sure the summing beam does not bind on the spool throughout the full travel of the summing beam. Tighten the two machine screws.
6. Be sure the spool head and summing beam remain engaged, but do not bind up, over the entire operating range of the input module.

Assembling the Feedback Shaft (Cam Shaft)

1. Inspect the feedback shaft (key 38). Be sure the shaft is free from any damage. Inspect the flanged bearings (key 17) and spacer (key 69). Replace, if necessary.
2. Properly install the flanged bearings in the positioner base plate. Install the spacer on the feedback shaft. Insert the shaft with spacer through the bearings and base plate. Make sure the feedback shaft rotates freely.
3. Install the washer (key 39) and retaining ring (e-clip) (key 40) that hold the feedback shaft in place.
4. Attach the cam (key 36) and cam locknut (key 37).
5. Set the initial cam position following the procedures given in this manual, if necessary.

Replacing the Feedback Arm Assembly and Span Adjuster Assembly

Note

The zero adjustment locknut and zero adjustment knob are identical parts, key 35.

Note

To identify the span adjuster assembly for 0.4 to 2.0 bar (6 to 30 psig) input range, red color coding appears on the range spring.

1. Make sure the zero adjustment knob (key 35) is installed on the span adjustment shaft (threaded rod) before installation into the zero adjustment pivot. Install the span adjustment assembly by sliding the threaded rod through the zero adjustment pivot on the feedback arm. Install the zero adjuster locknut on the threaded rod.
2. Install the cam roller (key 23) and shoulder screw (key 24). Be sure the cam roller rotates freely.
3. Place the flanged bearing (key 22) and feedback arm assembly on the feedback pivot. Place the washer (key 26) on the pivot and install the retaining ring (e-clip) (key 27) to secure the feedback arm on the feedback pivot.
4. If necessary, attach the cam (key 36) and cam locknut (key 37) to the feedback shaft.
5. Perform the calibration procedures in this manual.

3722 Converter Maintenance

Replacing the Converter Primary O-Ring and Filter

Key numbers used in this procedure are shown in figure 32.

1. Locate and remove the nozzle restriction adaptor assembly (key 75).
2. Inspect and replace, if necessary, the O-rings (keys 76 and 77). Apply lubricant (key 82) to the O-ring before replacing.
3. Inspect and replace the filter cartridge (key 88).

Disassembling the 3722 Converter

See figure 31 for key number locations.

1. Turn off electrical power to the converter. Release all supply pressure from the positioner.
2. Remove the cap (key 72) and disconnect the field wiring from the terminal block.
 - If a grounding wire is used inside the housing compartment, disconnect the wire from the internal housing ground screw (key 81).
 - If an external grounding wire is used, disconnect the grounding wire from the external ground screw (key 81).
3. To remove the converter module, remove the two screws (key 80) and pull the module out of the housing. Inspect the O-ring (key 77) and replace it, if necessary.
 - If you are removing the converter assembly from the pneumatic positioner, continue with steps 4 and 5. Or:
 - If you are replacing the converter module only, obtain a replacement converter module and refer to the procedure for assembling the converter. After replacing the converter module, calibrate the pneumatic portion of the positioner by performing the calibration procedures. There is no converter module calibration.
4. Disconnect the supply tubing, output tubing, and conduit from the converter.
5. Remove the two socket head screws (key 84) and remove the converter from the positioner base plate (key 16, figure 31). Inspect the two O-rings (key 85) and replace them if necessary. Apply lubricant (key 82) to the O-rings before replacement.

Assembling the 3722 Converter

Refer to figure 32 for key number locations, unless otherwise indicated, while assembling the converter. If the converter was removed from the pneumatic positioner, re-install using the following instructions.

1. Inspect the O-rings (key 85) and replace, if necessary. If the O-rings are in good condition, apply lubricant (key 82) to the O-rings and install them in the recessed areas surrounding the input and supply ports on positioner base plate (key 16, figure 31). Be sure the O-rings remain in place.
2. Apply sealant (key 64 or 83) to the two socket head screws (key 86). Then, properly align the converter and attach it to the positioner base plate using the socket head screws. Be sure the O-rings remain in place. Tighten the socket head screws.
3. Apply sealant (key 64 or 83) and install pipe bushings (key 68), pipe tees (key 56), gauges (key 53, 54, or 55), pipe plugs (key 57 or 86), tire valves (key 62), or diagnostic connectors as applicable to the converter.
4. If the converter module was removed from the housing, apply lubricant (key 82) to the O-ring (key 77) and insert the converter module into the housing.
5. Replace the two screws (key 80) and tighten them.
6. Connect the supply tubing, output tubing, and conduit to the converter.
7. Connect the wiring to the terminal block by using installation procedures.
 - If an internal grounding wire is used inside the housing compartment, connect the wire to the internal housing ground screw (key 81).
 - If an external grounding wire is used, connect the grounding wire to the external ground screw (key 81).
8. Inspect the O-ring (key 79) inside the converter cap (key 72). Replace, if necessary. Lubricate (key 82) the O-ring and install it inside the cap.
9. Lubricate (key 87) the threads of the cap and replace it.
10. If the converter module was replaced, calibrate the pneumatic portion of the positioner by performing the procedures in the Calibration section of this manual. Do not attempt to calibrate the converter module. There are no converter module adjustments.

Testing the 3722 Converter Module

Check the operation of the converter module by installing a pressure gauge in the instrument output port in the converter housing.

1. Remove the pipe plug (key 86, figure 32) in the instrument output port and connect a pressure gauge. Provide supply pressure and a 4 to 20 mA DC input signal.
2. Apply a 1.4 bar (20 psig) supply pressure. The instrument output pressure at a 4 mA DC input signal should be 0.16 to 0.24 bar (2.3 to 3.5 psig). The pressure output at a 20 mA dc input signal should be 0.97 to 1.07 bar (14.0 to 15.5 psig).
3. If necessary, replace the converter module and test the new module. Then, calibrate the pneumatic portion of the positioner by performing the procedures in the Calibration section of this manual. Do not attempt to calibrate the converter module. There are no converter module adjustments.

Parts Ordering

When corresponding with your [Emerson sales office](#) or Local Business Partner about this equipment, be sure to mention the positioner serial number.

⚠ WARNING

Use only genuine Fisher replacement parts. Components that are not supplied by Emerson Automation Solutions should not, under any circumstances, be used in any Fisher instrument. Use of components not supplied by Emerson may void your warranty, might adversely affect the performance of the instrument, and could cause personal injury or property damage.

Parts Kits

Description	Part Number
Pneumatic Positioner Elastomers Kit Contains keys 2, 17, 19, 22, 23, 24, 29, 30B, 31, 36, 59 nitrile EPDM	R3710X00012 R3710X00022
Electro-Pneumatic Converter Kit Contains keys 76, 77, 79, 85, 88 nitrile EPDM	R3722X00012 R3722X00022

Parts List

Note

Contact your [Emerson sales office](#) or Local Business Partner for Part Ordering information.

Positioner Common Parts (refer to figure 31)

Key Description

1*	Spool Valve Ass'y, 6 mm
2*	O-ring, used between spool valve and action block (3 req'd)
3 ⁽¹⁾	Screw (metric), slot-head/cross-recessed, For attaching action block to positioner base plate (4 req'd) For attaching spool valve to action block (2 req'd) For attaching input module to positioner base plate (4 req'd)
Note	
To identify the span adjuster ass'y for 0.4 to 2.0 bar (6 to 30 psig) input range, red color coding appears on the range spring.	
4	Span adjuster ass'y 0.2 to 1.0 bar (3 to 15 psig) (no color-coding) 0.4 to 2.0 bar (6 to 30 psig) (color-coded red)
5	Nameplate, positioner
6	Screw, self-tapping, pan head, slotted, for positioner nameplate (2 req'd)
7	Cover ass'y, includes screws (key 8) and O-rings (key 7B)
7B*	O-ring, used to hold positioner cover screws (4 req'd)
8 ⁽¹⁾	Screw (metric), slot-head/cross-recessed, For indicator cover (4 req'd) For positioner cover (captive) (4 req'd)
9	Hex nut (4 req'd) For indicator cover screws (key 8)
10	Beacon indicator
11	Extension feedback shaft, for use with beacon indicator
12 ⁽¹⁾	Retaining ring (E-clip) (metric) Used to secure the indicator. For standard indicator, use inside the positioner cover For beacon indicator, use outside the positioner cover

Key Description

Note

Key 13, pointer, is used with key 15, indicator. Key 13, pointer, fits over the molded slot in the center of key 15 and rests in appropriate quadrant recess in the surface of key 15.

13	Pointer
14	Indicator scale

Note

Key 15, indicator, features a molded slot to facilitate adjustment of the indicator during installation of the positioner cover.

15	Indicator w/molded screwdriver slot w/O-ring (key 15A)
----	--

Note

Key 16, base ass'y, includes key 38, feedback shaft, and key 17, flanged bearing (qty 2) only. Key 16 does not include key 18, supply cover, key 19, O-ring, and key 70, screw (qty 2).

16	Base ass'y
17*	Flanged bearing For feedback shaft (key 38) (2 req'd)
18	Supply cover
19	O-ring, used under the supply cover (key 18)
21	Feedback arm ass'y Includes needle bearing (key 25) pressed into the feedback arm
22*	Flanged bearing For feedback pivot
23*	Cam roller (ball bearing, metric) The bearing is used as the cam roller, attached to the feedback arm ass'y (key 21) by the shoulder screw (key 24)
24 ⁽¹⁾	Shoulder screw (metric)

Note

The needle bearing (key 25) is pressed into the feedback arm (key 21). To install a new needle bearing, the existing bearing must be pressed out. Consult your [Emerson sales office](#) or Local Business Partner.

25	Needle bearing
26 ⁽¹⁾	Washer (metric)
27 ⁽¹⁾	Retaining ring (e-clip) (metric)

Figure 31. Fisher 3710 Components and Subassemblies

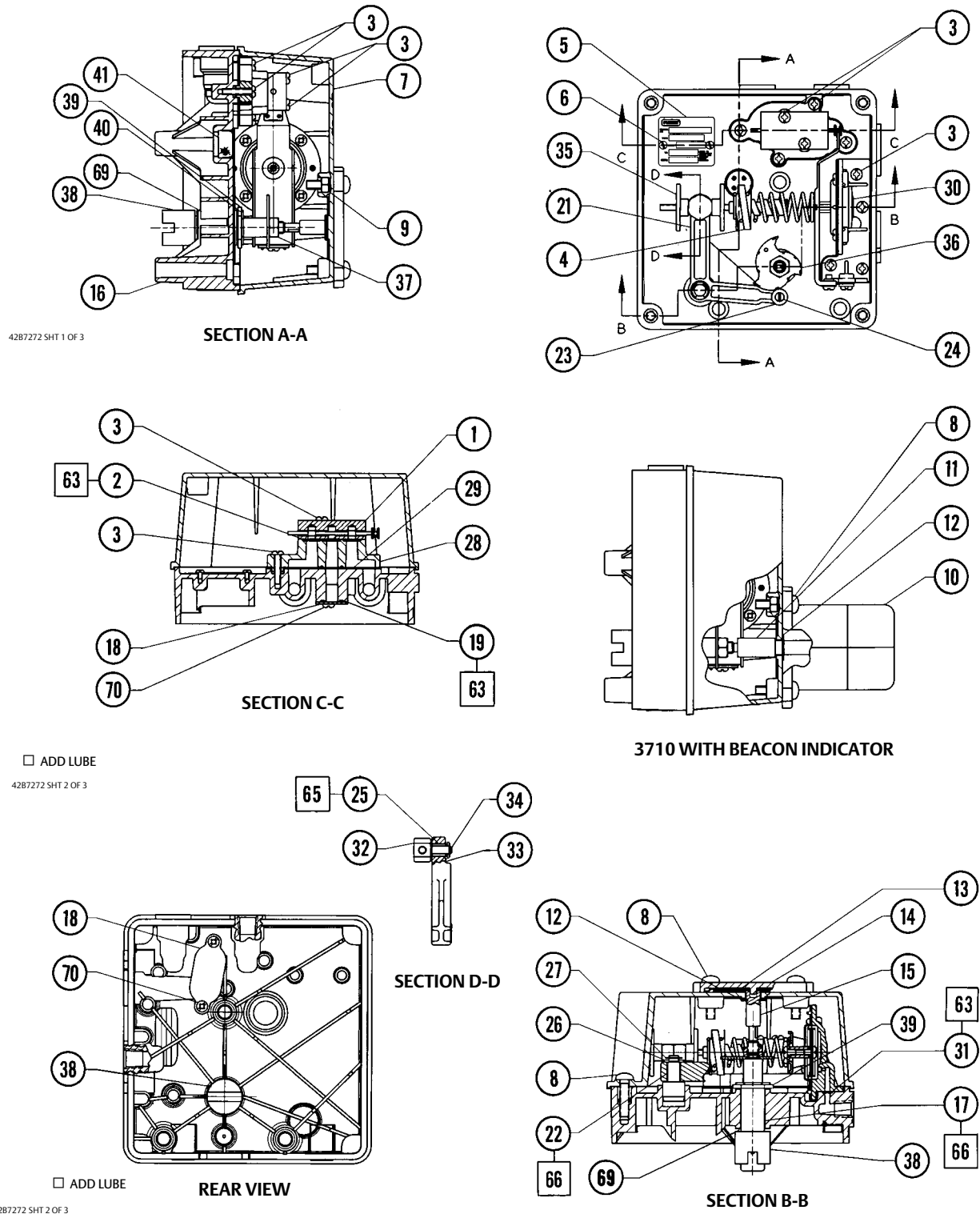
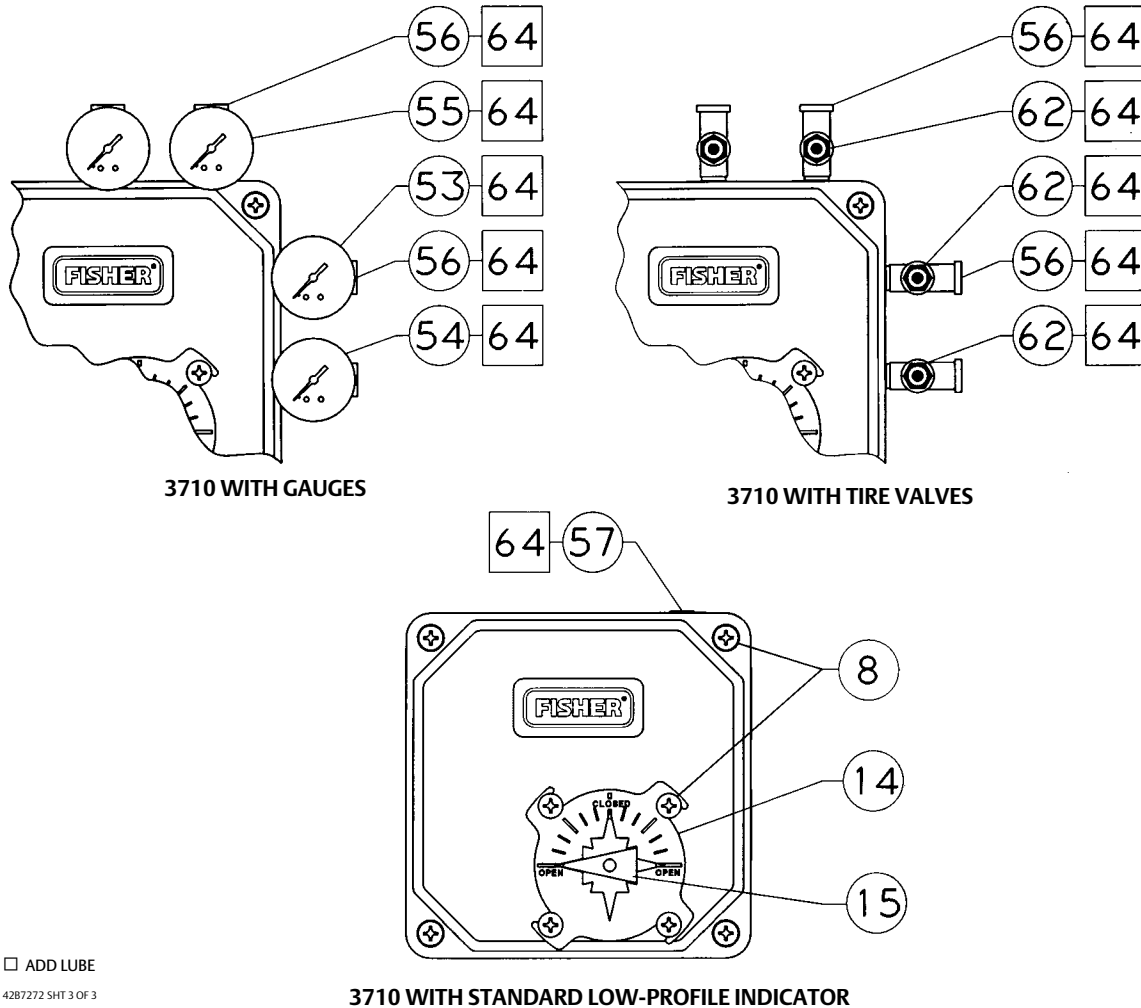

Figure 31. Fisher 3710 Components and Subassemblies (continued)



□ ADD LUBE

4287272 SHT 3 OF 3

Key	Description
28	Action block
29*	Action block gasket
30*	Input module assy Includes summing beam assy and flexure
31*	O-ring For use between input module assy and positioner base plate
32	Zero adjustment pivot
33 ⁽¹⁾	Washer (metric) For zero adjustment pivot

Key	Description
34 ⁽¹⁾	Retaining ring (E-clip) (metric) For zero adjustment pivot

Note

Two zero adjusters (key 35) are required: one for the zero adjustment locknut and one for the zero adjustment knob.

35	Zero adjuster (2 req'd)
36*	Cam Rotary Valves, std 90 deg rotation Sliding-Stem Valves
37 ⁽¹⁾	Cam locknut (hex/metric)

Key	Description	Part Number
38	Feedback shaft (cam shaft)	
39 ⁽¹⁾	Washer (metric) For feedback shaft (cam shaft) (key 38)	
40 ⁽¹⁾	Retaining ring (e-clip) (metric) for feedback shaft (cam shaft) (key 38)	
41	Vent screen	

Note

To attach a gauge or tire valve to the positioner or converter, use a pipe nipple (key 68) and a street tee (key 56).

53*	Supply gauge, plastic case, W/chrome-plated brass connection (requires street tee, key 56) 0 to 30 psig/0 to 0.2 MPa/0 to 2 bar 0 to 60 psig/0 to 0.4 MPa/0 to 4 bar 0 to 160 psig/0 to 1.1 MPa/0 to 11 bar	11B4040X012 11B4040X022 11B4040X032
54*	Instrument gauge, plastic case, W/chrome-plated brass connection (requires street tee, key 56) 0 to 30 psig/0 to 0.2 MPa/0 to 2 bar 0 to 60 psig/0 to 0.4 MPa/0 to 4 bar	11B4040X012 11B4040X022
55*	Output gauge, plastic case w/chrome-plated brass connection (requires street tee, key 56) 0 to 30 psig/0 to 0.2 MPa/0 to 2 bar 0 to 60 psig/0 to 0.4 MPa/0 to 4 bar 0 to 160 psig/0 to 1.1 MPa/0 to 11 bar (single or double action)	11B4040X012 11B4040X022 11B4040X032
56	Street tee, qty 1, required to attach each gauge or tire valve to pipe bushing (key 68)	
57	Pipe plug, for single-acting positioners only	
62	Tire valve Single action (1 req'd) or Double action (2 req'd)	
63	Lubricant, silicone sealant, (not furnished with positioner)	
64	Anti-seize sealant (not furnished with positioner)	
65	Lubricant, 20W/50 Motor Oil or equivalent (not furnished with positioner)	
66	PTFE Petroleum based lubricant (not furnished with positioner)	

Key	Description
68	Pipe bushing, qty 1, required to attach each pipe tee (key 56) to positioner connection
69	Spacer, installed between the feedback shaft (key 38) and the positioner base plate
70 ⁽¹⁾	Screw (metric), slot-head/cross-recessed Used to secure key 18, supply cover, to key 16, base ass'y (2 req'd)

Diagnostic Connections (refer to figure 16)

FlowScanner valve diagnostics system hook-up

Includes pipe tee, pipe nipple, pipe bushings, connector body, and body protector. If ordered for units with gauges, a stem is also included.

For 3710 Positioner

Single-acting units
For units w/gauges
For units w/o gauges

Double-acting units
For units w/gauges
For units w/o gauges

For 3720 Positioner

Single-acting units
For units w/gauges
For units w/o gauges

Double-acting units
For units w/gauges
For units w/o gauges

* Recommended spare parts
1. Also recommended as a spare if metric fasteners are not available at the installation site.

3722 Electro-Pneumatic Converter (refer to figure 32)

Key Description

- 71 Housing
1/2-14 NPT conduit connection
- 72 Cap
- 73 Screw (not shown)
used to secure explosion-proof cap
- 75 Nozzle restriction
- 76 O-ring
Used w/nozzle restriction, key 75

Key Description

- 77* O-ring
For use w/nozzle restriction, key 75
For use w/converter module, key 89
- 78 Vent
- 79* O-ring
Used with converter cap, key 72
- 80 Machine screw (2 req'd)
- 81 Wire retaining screw
Used as a grounding screw for both
internal and external locations
includes square washer (2 req'd)

Figure 32. Fisher 3722 Components and Subassemblies

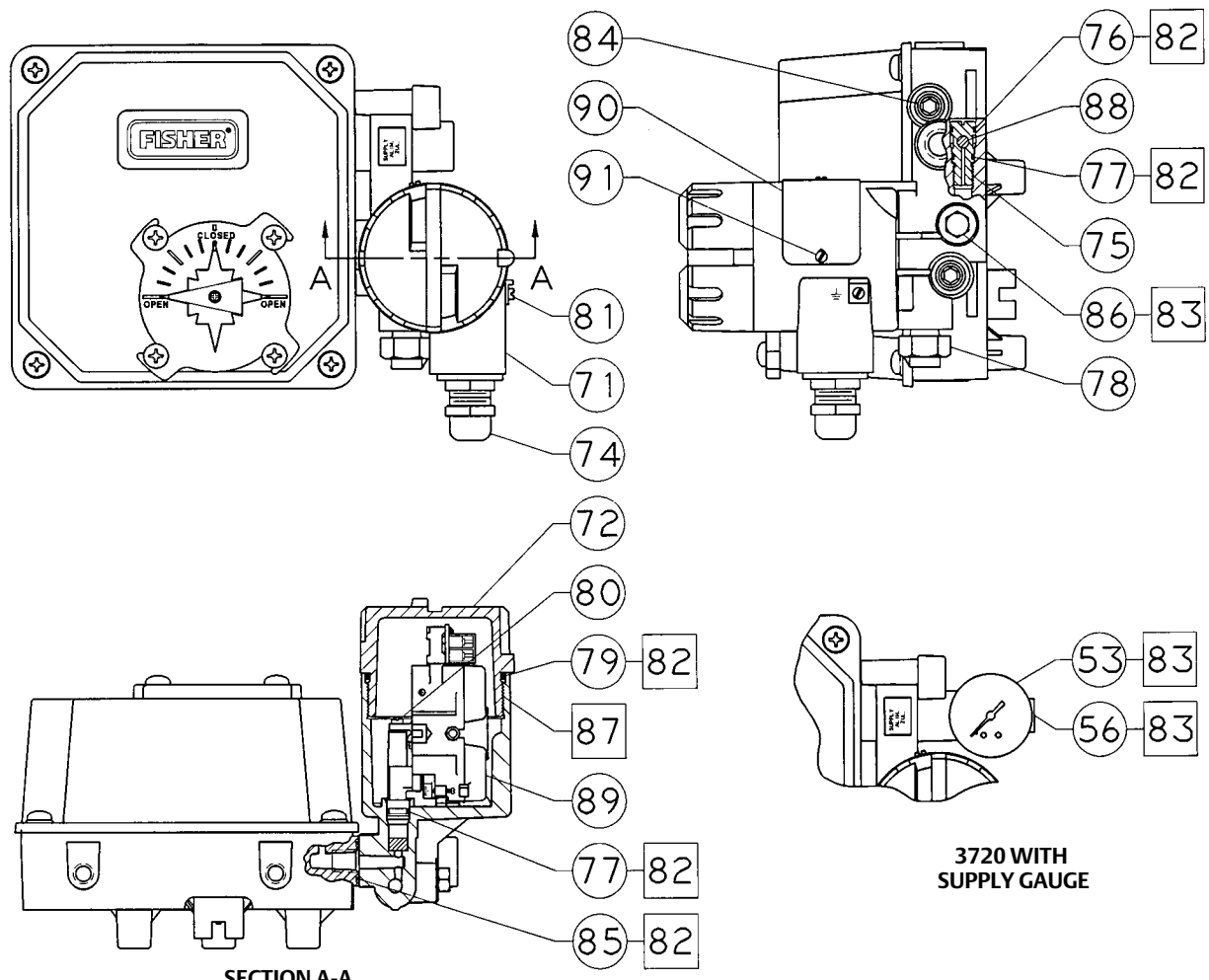

□ APPLY LUB/SEALANT
3480694-A

**3720 WITH
SUPPLY GAUGE**

Key	Description
82	Lithium Grease (not furnished with positioner)
83	Anti-seize Sealant (not furnished with positioner)
84	Cap screw, hex socket For attaching the converter to the positioner base plate (2 req'd)
85*	O-ring (2 req'd) Used between positioner base plate and converter
86	Pipe plug, hex head
87	Anti-seize Lubricant (not furnished with positioner)
88*	Filter
89	I/P converter module
90	Nameplate, converter module
91	Screw, self-tapping, pan head, slotted, for positioner nameplate (2 req'd)

Positioner Mounting Parts (refer to figure 33)

Note

To mount the 3710 or 3720 positioner to an existing actuator, replace the actuator cover plate with a new plate which has the three positioner mounting holes and the 5/8-inch purge option knockout plug. Contact your [Emerson sales office](#) or Local Business Partner for any additional parts required for controller mounting.

Key	Description
	Actuator cover plate
	For 1051/1052 size 30 ⁽²⁾ , 40 and 1061 size 30
	For 1051 size 60, 1052 size 60, 70, and 1061 size 30, 40, 60

Key	Description
42	Tie bar For 1051/1052 size 33 and 1066 size 20, use tie bar extension (key 44) instead of the tie bar (key 42) For 1051/1052 sizes 30 ⁽²⁾ , 40, 60 For 1052 size 20, size 70 For 1061 sizes 30, 40, 60, 68, sizes 80, 100 For 1066 size 27, size 75
43	Mounting plate For 1052 size 20 For 1051/1052 size 33 For 1061 sizes 80, 100 For 1066 size 20, 27, size 75 For 2052 size 1, 2, 3
44	Tie bar extension For 1051/1052 size 33 For 1066 size 20 For 2052 size 1, 2, 3
45	Cap screw, hex head For attaching the mounting plate to the actuator cover plate For 1052 size 20 (4 req'd) For 1051/1052 size 33 (2 req'd) For 1066 size 20, size 27, size 75 (2 req'd) For 2052 size 1, 2, 3
46	Cap screw, hex socket For attaching the positioner base plate to the mounting plate or actuator cover plate For 1051/1052 sizes 30 ⁽²⁾ , 40, 60; 1052 size 70; 1061 sizes 30, 40, 60, 68 (3 req'd) For 1051/1052 size 33; 1052 size 20; 1061 sizes 80, 100; and 1066 sizes 20, 75 (3 req'd) For 1066 size 27 (3 req'd) For 1066 size 75 (3 req'd) For 2052 size 1, 2, 3

*Recommended spare parts

2. The size 30 actuator is no longer manufactured by Emerson. The 3710 positioner is available for field installation on existing size 30 actuators.

Figure 33. Positioner Mountings

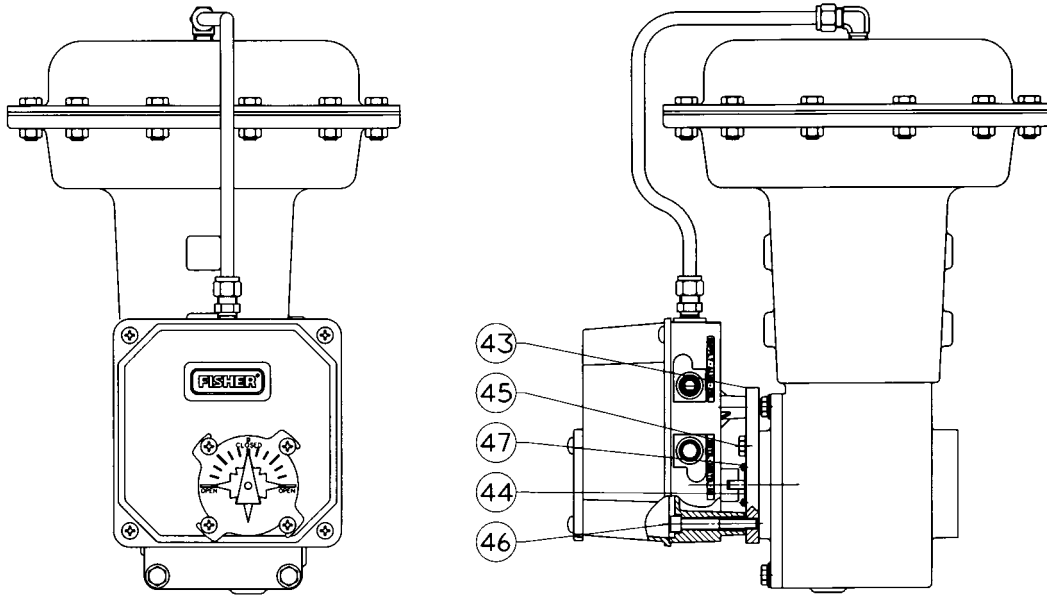

42B8478-A

3710 POSITIONER MOUNTED ON A
1051/1052 SIZE 33 ACTUATOR

Key Description

- 47 Machine screw, self-tapping
For attaching the tie bar or tie bar extension to the actuator hub

For 1051/1052 sizes 30⁽²⁾, 40, 60; 1052 size 70; 1061 sizes 30, 40, 60, 68 (2 req'd)
For 1052 size 20 (2 req'd)
For 1051/1052 size 33 (2 req'd)
For 1061, sizes 80, 100 (2 req'd)
For 1066 sizes 20, 27 (2 req'd)
For 1066 size 75 (2 req'd)
For 2052 size 1, 2, 3 (2 req'd)
- 58 Purge tube
For 1051/1052 sizes 30⁽²⁾, 40, 60; 1052 size 70; 1061 sizes 30, 40, 60, 68

Key Description

- 59* O-ring, purge tube (2 req'd)
- 60 Coupling
For 1061 sizes 80, 100
For 1066 size 27
- 61 Spacer
For 1066 size 27 (3 req'd)
For 2052 size 1, 2, 3 (3 req'd)

*Recommended spare parts
2. The size 30 actuator is no longer manufactured by Emerson. The 3710 positioner is available for field installation on existing size 30 actuators.

Figure 33. Positioner Mountings (Continued)

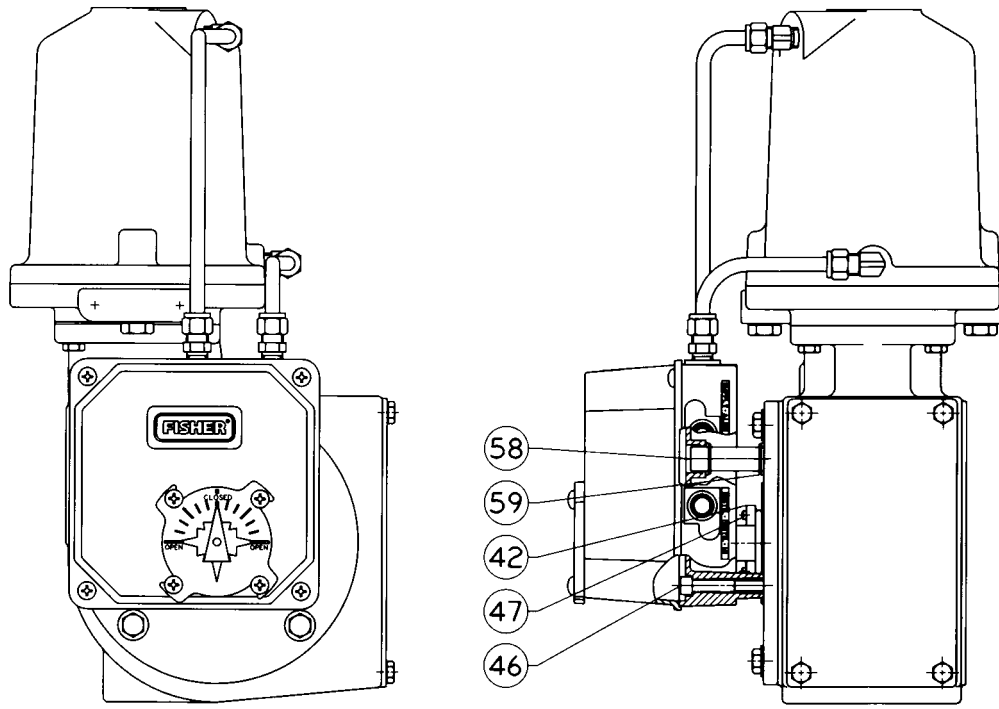

42B8466-A

3710 POSITIONER MOUNTED ON A
1051/1052 SIZE 30 THROUGH 70 OR 1061 ACTUATOR

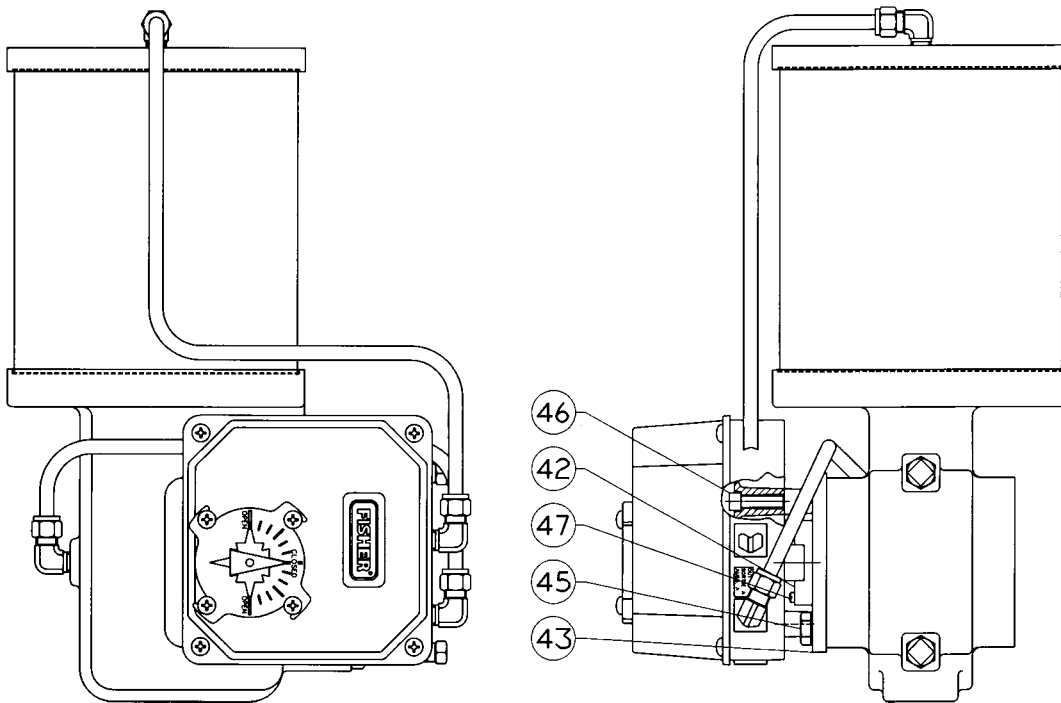

42B8484-A

3710 POSITIONER MOUNTED ON A 1066 SIZE 75 ACTUATOR

Mounting Parts for Mounting Positioner on 585 and 585R Actuators (refer to figures 7, 8, and 9 unless otherwise noted)

38	Feedback Shaft (see figure 31)
43	Mounting Plate
45	Cap Screw
46	Cap Screw
61	Spacer
92	Lock washer
93	Cap Screw
94	Feedback Lever
95	Drive Stud
96	Hex Nut
97	Mounting Bearing
98	Drive Stud Bracket
99	Cap Screw
100	Lock washer
101	Roller Bearing
102	E-Ring
103	Washer
	Pipe Nipple, for mounting the 67 Filter Regulator

Fittings

Key Description

Note

Contact your [Emerson sales office](#) or Local Business Partner for descriptions of fittings, including materials of construction. Specify quantity of fittings required.

50	Elbow
51	Connector
52	Swivel

Neither Emerson, Emerson Automation Solutions, nor any of their affiliated entities assumes responsibility for the selection, use or maintenance of any product. Responsibility for proper selection, use, and maintenance of any product remains solely with the purchaser and end user.

Fisher and FlowScanner are marks owned by one of the companies in the Emerson Automation Solutions business unit of Emerson Electric Co. Emerson Automation Solutions, Emerson, and the Emerson logo are trademarks and service marks of Emerson Electric Co. All other marks are the property of their respective owners.

The contents of this publication are presented for informational purposes only, and while every effort has been made to ensure their accuracy, they are not to be construed as warranties or guarantees, express or implied, regarding the products or services described herein or their use or applicability. All sales are governed by our terms and conditions, which are available upon request. We reserve the right to modify or improve the designs or specifications of such products at any time without notice.

Emerson Automation Solutions
Marshalltown, Iowa 50158 USA
Sorocaba, 18087 Brazil
Cernay, 68700 France
Dubai, United Arab Emirates
Singapore 128461 Singapore

www.Fisher.com

